

**PERTH AMBOY BUSINESS IMPROVEMENT DISTRICT
CITY HALL
260 High Street, Perth Amboy, NJ 08861
(732) 442-6421**

**PERTH AMBOY BUSINESS IMPROVEMENT DISTRICT
PUBLIC MEETING**

Pursuant to the Open Public Meetings Act, please note that a regular public meeting has been scheduled for the Perth Amboy Business Improvement District to take place on **Tuesday, December 14, 2021 at 4:00 p.m.** at City Hall Council Chambers located at 260 High Street, Perth Amboy.

Notice of this meeting has been given to the Star Ledger, the Home News Tribune, the Amboy Guardian, published on the City's website, BID board webpage, provided to the City Clerk's office for public posting (bulletin board), released via Constant Contact email service.

AGENDA

I. Salute to the Flag

II. Roll Call

Name	Present	Absent	Excused
Antonio Abreu			
Fausto Diaz			
Iris Diaz			
Mayor Helmin Caba			
Sergio Diaz			
Lisett Lebron			
Asim Malik			
Reyes Ortega			
Samuel Quezada			
<i>Mayor's Designee*</i>			
Barry Rosengarten			
Elizabeth Sanchez			
James Snyder			

III. **Approval of Minutes** November 9, 2021

Motion _____
Second _____

Approval of Minutes November 15, 2021

Motion _____
Second _____

IV. **Approval of December Bill List** Lisett Lebron, Board Member
\$11,961.66

Motion _____
Second _____

V. **Chairman's Report** Barry Rosengarten, Chairman

- a. BID Updates
 - 1) City Council Approved the CY 2022 BID Budget
 - 2) Annual Meeting Notice for 2022
- b. 2022 Fireworks
- c. Tort Claim Notice

VI. **Manager's Report** Noelia Colon, Executive Director

- a. 2021 Annual Report
- b. BID/NPP Art Initiatives (Pop-Up Art)
- c. Holiday Parking Notice, Nov. 26th – Jan 1st, 2022
- d. Events
 - 1) Santa Visits Downtown Perth Amboy

VII. **Committee Report**

- a. By-Laws Committee Sergio Diaz, Chair
- b. Façade Grant James Snyder, Chair
 - 1) Bay City Restaurant and Sports Bar - 273 High Street
 - 2) Santibana Travel/HFI Insurance Agency- 362 State Street
 - 3) Towns Drugs & Surgical - 164 Smith Street
 - 4) Inman Medical Care Center - 322 State Street
 - 5) Aleah Multi-Service – 313 State Street, Suite 103

VIII. **Old Business:**
None

IX. **New Business:**
None

X. **Public Portion:**

Motion to open the public portion:

Motion _____
Second _____

Motion to close the public portion:

Motion _____
Second _____

XI. Adjourn:

Motion _____
Second _____

**PERTH AMBOY BUSINESS IMPROVEMENT DISTRICT
CITY HALL
260 High Street, Perth Amboy, NJ 08861
(732) 442-6421**

**PERTH AMBOY BUSINESS IMPROVEMENT DISTRICT
PUBLIC MEETING**

Pursuant to the Open Public Meetings Act, please note that a regular public meeting has been scheduled for the Perth Amboy Business Improvement District to take place on **Tuesday, November 9, 2021 at 4:00 pm** at City Hall Council Chambers located at 260 High Street, Perth Amboy.

Notice of this meeting has been given to the Star Ledger, the Home News Tribune, the Amboy Guardian, published on the City's website, BID board webpage, provided to the City Clerk's office for public posting (bulletin board), released via Constant Contact email service.

MINUTES

I. Salute to the Flag

II. Roll Call

Name	Present	Absent	Excused
Antonio Abreu	x		
Fausto Diaz	x		
Iris Diaz		x	
Mayor Helmin Caba	x		
Sergio Diaz	x		
Lisett Lebron	x		
Asim Malik		x	
Reyes Ortega	x		
Samuel Quezada	x		
<i>Mayor's Designee*</i>			
Barry Rosengarten	x		
Elizabeth Sanchez		x	
James Snyder	x		

III. **Approval of Minutes**

October 12, 2021

Motion S. Quezada
Second J. Snyder
All in Favor

IV. **Approval of November Bill List
\$55,091.94**

Reyes Ortega, Treasurer

Motion S. Diaz
Second J. Snyder
All in Favor

V. **Chairman's Report**

Barry Rosengarten, Chairman

a. BID Updates

1) 2020 Audit Report – Robert Butvilla, Auditor

1. *Chairman Rosengarten: We have our auditor present to provide information regarding the 2020 audit. No findings in the 2020 audit report.*

2) Budget Introduction Passed City Council Meeting

1. *Chairman Rosengarten: BID represented before the City Council on the 2022 proposed budget. They have introduced the budget and their public hearing will be taking place on 11/22/2021.*

3) Budget Public Hearing – 11/15/2021 at 5:00 p.m.

1. *Chairman Rosengarten: Our public hearing will be taking place on 11/15/2021 at 5:00 pm, as stated in the timeline in the packet.*

4) Accounting Report and Services

1. *Chairman Rosengarten: Please see the accounting report in your packets. As you recall from the approval of the board last month, Ospino consulting proceed with an evaluation and report and her minor findings were upgrading the version of Quick books. As per our request, she also provided rates for monthly accounting services. Attached you will find her workflow and services log at a rate request of \$800 per month, which would include, NJ annual reporting, bank reconciling, posting of invoices and transitions, monthly reporting, expense monitoring, processing payments to vendors, budget management, and online annual quick books membership. Please share your thoughts on the bringing an accountant on board.*

***Motion presented to approve November to end of Q1 for CY 2022.
(November 1st to – March 30th)***

Motion: S. Diaz

Second: A. Abreu

All in Favor

5) 2022 Fireworks

Notes: Proposed, BID expansion funds will support the Fireworks.

VI. Manager's Report

Noelia Colon, Executive Director

Events

- 1) Floral Pop-Up Exhibit | 11/2/2021 – 11/30/2021
- 2) Small Business Saturday/Winter Wonderland | 11-27-2021
- 3) *Classic Car Show- (add on)*

Notes: Plan to reschedule for Spring of 2022.

VII. Committee Report

By-Laws Committee

Sergio Diaz, Chair

Notes: We met once and will be meeting again to review by laws of other communities to make changes to our by-laws.

VIII. Old Business:

Director Sergio Diaz: Provide BID material to Code Enforcement so that their department promotes our façade grants and BID other resources.

Director James Snyder: Request a formal letter from business owners who apply/applied for façade grant and have submitted their application after they received their new signage. Provide a letter of hardship, if impacted by the pandemic. Also, these additional suggestions were made, (1) add to the new application that non-profits in the BID district that can apply, (2) cap the non-profit number, (3) find some flexibility in the number of bids requested (4) repurpose other unexpended funds to make more façade grants available.

IX. New Business:

None

X. Public Portion:

Motion to open the public portion:

Motion S. Diaz
Second J. Snyder
All in Favor

Dania Arias (public member) – she is interested in seeing that facade grants and other BID resources are extended business outside of the BID area.

Motion to close the public portion:

Motion S. Diaz
Second J. Snyder
All in Favor

XI. Adjourn:

Motion S. Diaz
Second J. Snyder
All in Favor

**PERTH AMBOY BUSINESS IMPROVEMENT DISTRICT
CITY HALL
260 High Street, Perth Amboy, NJ 08861
(732) 442-6421**

**PERTH AMBOY BUSINESS IMPROVEMENT DISTRICT
PUBLIC MEETING**

Pursuant to the Open Public Meetings Act, please take notice that a public hearing has been scheduled for the Perth Amboy Business Improvement District and will take place on **Monday, November 15, 2021 at 5:00 p.m.** at the City Hall Council Chamber, 260 High Street, Perth Amboy, New Jersey. Notice of this meeting has been given to the Star Ledger, the Home News Tribune, the Amboy Guardian, mailed to BID business/property owners, posted on the City's website and BID webpage and posted in the bulletin board at the City Clerk's Office.

MINUTES

I. Salute to the Flag

II. Roll Call

Name	Present	Absent	Excused
Antonio Abreu	x		
Fausto Diaz	x		
Iris Diaz		x	
Mayor Helmin Caba	x		
Sergio Diaz		x	
Lisett Lebron	x		
Asim Malik		x	
Reyes Ortega	x		
Samuel Quezada	x		
Barry Rosengarten	x		
Elizabeth Sanchez		x	
James Snyder		x	

III. **Public Discussion on the CY 2022 proposed budget for the Business Improvement District.**

Public Portion:

Motion to open the public portion:

Motion A. Abreu
Second S. Quezada
All in Favor

Motion to close the public portion:

Motion A. Abreu
Second L. Lebron
All in Favor

*Motion to approve the CY 2022 Proposed Budget
Resolution 09/11-21*

Motion R. Ortega
Second S. Quezada
All in Favor

*A. Abreu: mentioned businesses complaining about the admin issuing parking tickets
being given on Amboy Avenue and State Street.*

IV. **Adjourn:**

Motion S. Quezada
Second R. Ortega
All in Favor

**RESOLUTION
BY THE BOARD OF DIRECTORS OF
DOWNTOWN PERTH AMBOY BUSINESS IMPROVEMENT DISTRICT, INC. (BID)
APPROVING THE 2022 OPERATING BUDGET IN THE AMOUNT OF \$247,650**

WHEREAS, the BID Assessment is anticipated in the amount of \$247,650;

WHEREAS, on Monday, November 15, 2021, the Perth Amboy BID Board of Directors, by way of a majority vote, approved the 2022 operating budget in the amount of \$247,650.

NOW, THEREFORE, IT IS HEREBY RESOLVED, by the Board of Directors of the Perth Amboy Business Improvement District (BID) by approved

1. The 2022 operating budget of the BID be approved and adopted as recommended.

ADOPTED this 15th of November 2021 at a duly noticed meeting,

**DOWNTOWN PERTH AMBOY BUISNESS
IMPROVEMENT DISTRICT, INC.**

Barry Rosengarten, Chairman

Antonio Abreu, Secretary

ATTEST to form:

Noelia Colon, BID Executive Director

November 15, 2021

VOTING:

First Name	Last Name	YES	NO	Abstain	Excused
Lisett	Lebron	x			
Reyes	Ortega	x			
Samuel	Quezada	x			
Elizabeth	Sanchez				
Fausto	Diaz	x			
James G.	Snyder				
Sergio	Diaz				
Antonio	Abreu	x			
Asim	Malik				
Iris	Diaz				
Mayor Helmin	Caba	x			
Chairman Barry	Rosengarten	x			

**PERTH AMBOY
BUSINESS IMPROVEMENT DISTRICT**

**DECEMBER 2021
AS OF 11/9/2021
BILL LIST**

Name	Date	Description	Open Balance
Illusion Engraved	11/9/2021	Namedesk plate replacement for Executive Director	\$ 30.00
		Total	\$ 30.00
NJ League of Municipalities	11/16/2021	NJLM Conference Registration	\$ 70.00
		Total	\$ 70.00
Shevchenko Monuments LLC	11/19/2021	Perth Amboy War Memorial name inscriptions	\$ 2,280.00
		Total	\$ 2,280.00
The Amboy Guardian	11/22/2021	SBS Winter Wonderland Ad full page	\$ 525.00
		Total	\$ 525.00
Printing Copy Center	11/24/2021	Business Cards for Small Business Saturday	\$ 35.00
		Total	\$ 35.00
Noelia Colon	12/1/2021	Reimbursement for Travel for NJLM Conference	\$ 140.96
		Total	\$ 140.96
Veronica Pacheco	11/30/2021	Vendor Services: November 1- November 30	\$ 592.50
		Total	\$ 592.50
Verizon	11/24/2021	BID Phone payment; October 25- November 24	\$ 73.85
		Total	\$ 73.85
Piasecki & Whitelaw LLC	12/5/2021	Legal Services	\$ 2,100.00
		Total	\$ 2,100.00
PashmanStein WalderHayden	12/6/2021	Professional Legal Services for November 2021	\$ 2,940.38
		Total	\$ 2,940.38
Printing Copy Center	12/10/2021	Holiday/Christmas Cards	\$ 165.00
		Total	\$ 165.00

**PERTH AMBOY
BUSINESS IMPROVEMENT DISTRICT**

**DECEMBER 2021
AS OF 11/9/2021
BILL LIST**

Dunkin Donuts	11/27/2021	Small Business Saturday- Hot Chocolate (two separate receipts)	\$ 620.73
		Total	\$ 620.73
Downtown NJ	11/16/2021	Annual Subscription, January 2022	\$ 300.00
		Total	\$ 300.00
Lincoln Signs	11/24/2021	Updated Street Banner Shop Local Campaign & Free 2-Hour Parking	\$ 794.50
		Total	\$ 794.50
Shevchenko Monuments LLC	12/10/2021	Remainder of Donation- Credit for future engravings (3114.59)	\$ 832.59
		Total	\$ 832.59
Gannet NJ	12/20/2021	Public Notice	\$ 22.36
		Total	\$ 22.36
Essential Communicaitons	12/16/2021	PR Services for Food Tour	\$ 250.00
		Total	\$ 250.00
Amboy Guardian	12/13/2021	Holiday Ad	\$ 174.00
		Total	\$ 174.00
Shoprite	11/24/2021	Disposable Cups for SBS (Qty: 400)	\$ 14.79
		Total	\$ 14.79
		TOTAL	\$ 11,961.66

Total Bill List	\$ 11,961.66
Date	12/14/2021

NAME	APPROVED
Antonio Abreu	
Lisett Lebron	
Asim Malik	
Sergio Diaz	
Mayor Helmin Caba	
Fausto Diaz	
Iris Diaz	
Reyes Ortega	
Samuel Quezada	
Elizabeth Sanchez	
James Snyder	
Chairman Rosengarten	

Motion:

Second:

FW: NJLM Registration Remittance Invoice {NJL211:18328}

1 message

Noelia Colon <ncolon@perthamboynj.org>
To: Perth Amboy Businesses <perthamboybusinesses@gmail.com>

Fri, Nov 19, 2021 at 10:05 AM

Please add to bill list and folder in drive for December invoices.

Noelia

From: NJLM Conference Registration [mailto:email_confirm@confmail.experient-inc.com]
Sent: Tuesday, November 16, 2021 1:07 PM
To: Noelia Colon <ncolon@perthamboynj.org>
Subject: NJLM Registration Remittance Invoice {NJL211:18328}

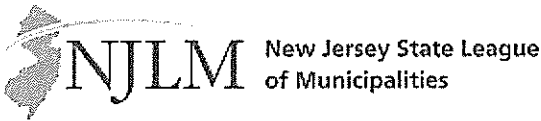

INVOICE
222 West State Street, Trenton, NJ 08608
Contact: Finance Department, Ext. 113 or 119
P: 609-695-3481

LEAGUE CONFERENCE | 106th ANNUAL | NOVEMBER 16 - 18, 2021

*** Please do not reply to this e-mail. It was sent from an automated system. ***

Payment and or completed purchase order certification is due within five (5) days from the date on this invoice

We do not accept faxed or emailed purchase orders or registration documents

Remittance Invoice – 7486

Received From:
Noelia Colon, Executive Director
PERTH AMBOY CITY
260 HIGH ST
PERTH AMBOY, NJ 08861-4491

11/16/2021

To:
NJLM
222 West State Street, Trenton, NJ 08608
Attention: Finance Department
(Write Invoice number on all checks and purchase orders)

Financial Summary

Total of All Fees: \$70.00

Total Amount Applied to All Fees:(\$70.00)

Total Balance Due: \$0.00

Online PO/Check Number:
Credit Card Payment: 2942

Registration Information for Invoice - 7486

Original Invoice Date: 11/16/2021

Key Contact

Confirmation ID: 18328
Noelia Colon, Executive Director
PERTH AMBOY CITY
260 HIGH ST
PERTH AMBOY, NJ 08861-4491

Our records indicate that you are the key contact and that you have obtained the proper authorization to make this purchase on behalf of your municipality and/ or organization.

Registration Detail

18328 - Noelia Colon - Executive Director - ncolon@perthamboynj.org - GOV - \$70.00

Payment History

Payment #1

11/16/2021 — \$70.00 [Payment]
Noelia Colon / Visa / *****2942

Payment Allocation

11/16/2021 — Applied: Noelia Colon's Registration \$70.00

Total Amount Applied: \$70.00

Total Amount Not Used: \$0.00

Payment Totals

Total Payments: \$70.00

Payment #1

Total Refunds: \$0.00

Total Net Paid: \$70.00

BADGE CORRECTIONS

On or before October 5, 2021, **corrections can only be made** to the spelling of a municipality name, company name, registrant's name, title and/or email address by making the correction(s) on your printed remittance invoice and email it to njlm@maritz.com.

After October 5, 2021, **corrections can only be made** to the spelling of a municipality name, company name, registrant's name, title and/or email address at the registration badge change counter on the second level of the Atlantic City Convention Center to the far right of Hall C beginning on Tuesday, November 16, 2021, at 9:00am.

BADGE MAIL DATE

For online registrations received between August 1 and October 22, badges will be mailed starting October 25, 2021.

For online registrations received between October 22 and November 12, badges must be picked up onsite via scan & print kiosks.

MAIL THE PAGE BELOW TO THE LEAGUE OFFICE WITH A CHECK, MONEY ORDER OR PURCHASE ORDER IF APPLICABLE

Remittance Invoice – 7486

Received From:
Noelia Colon, Executive Director
PERTH AMBOY CITY
260 HIGH ST
PERTH AMBOY, NJ 08861-4491

11/16/2021

To:
NJLM
222 West State Street, Trenton, NJ 08608
Attention: Finance Department
(Write Invoice number on all checks and purchase orders)

CLAIMANT'S CERTIFICATION DECLARATION

I do solemnly declare and certify under the penalties of the Law that the bill/invoice statement is correct in all its particulars; that the materials / articles have been furnished or services rendered as stated herein; that no bonus has been given or received by any person or persons within the knowledge of this claimant in connections with the above claim; that the amount therein stated is justly due and owing and that the amount charged is a reasonable one.

Federal ID#21 6000935

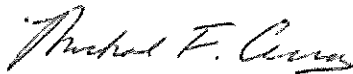

Michael Cerra, Executive Director

11/16/2021**CERTIFICATION AND PAYMENT:****Remittance Invoice – 7486**

1) Purchase Order Only

(*All fields below are required fields)

CERTIFICATION BY APPROVAL OFFICIAL

I certify that I am authorized to place this order and declare that this order is correct, and that sufficient funds are available to satisfy this claim.

Chargeable to Acct(s) (optional)

*Official PO #

*Total Due \$

*Print Name

*Title

*Signature

The above certification was approved by the Local Finance Board and meets the requirements for certification of performance of service. Your voucher for separate signature is not needed. Please complete the above in its entirety and return to NJLM.

If attaching the purchase order for signature check here: _____ and return this stub and PO to NJLM, 222 West State Street, Trenton NJ, 08608, Finance Department

Finance Department Address:

PRINT ADDRESS

(Write invoice number on PO's requiring signature. Save a copy of this remittance payment document to mail in with your check)

2) Enclosed Check #

Check Amount of \$

Check Date

(Submit this remittance invoice with your check. Write the invoice number in your check memo section)

Maritz Privacy Policy | Maritz Terms of Use

Links contained in this email have been replaced. If you click on a link in the email above, the link will be analyzed for known threats. If a known threat is found, you will not be able to proceed to the destination. If suspicious content is detected, you will see a warning.

Noelia Colon, BID/UEZ Executive Director

City of Perth Amboy

Business Improvement District

Email: ncolon@perthamboynj.org

Phone: (732) 442-6421

Website: www.perthamboynj.org

Receive alerts from the City of Perth Amboy: Text 08861 to 888777 for mobile alerts or sign up at <https://local.nixle.com/register/>

HELP PREVENT THE SPREAD OF COVID-19

MASK-UP ♦ KEEP 6 FEET APART ♦ SANITIZE AND WASH HANDS FREQUENTLY

DISCLAIMER: *The filters and firewalls needed in the current internet environment may delay receipt of emails, particularly those containing attachments. We strongly urge you to use delivery receipt and/or telephone calls to confirm receipt of important email.*

CONFIDENTIALITY NOTICE: *Some emails and files transmitted might be considered privileged and confidential that may also be considered advisory, consultative and deliberative (ACD) material under OPRA. If the reader of this e-mail is not the intended recipient or his or her authorized agent, the reader is hereby notified that any dissemination, distribution or copying of this e-mail is prohibited. If you have received this e-mail in error, please notify the sender by replying to this message and delete this e-mail immediately.*

WARNING: *Email received by or sent to City officials is subject to the Open Public Records Act (OPRA). This means that absent some specific privilege, all such communications are considered a public record and are subject to publication and/or dissemination to the public upon request.*

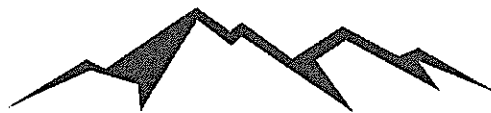

SHEVCHENKO MONUMENTS LLC.

4th Generation Craftsmen Since 1919

A Family Owned & Operated Factory Showroom

329 Florida Grove Road (Hopelawn) Perth Amboy, NJ 08816



11-19-21

Phone (732) 442-1286

www.shevco.com

Fax (732) 697-0418

THIS AGREEMENT is entered into with SHEVCHENKO MONUMENTS LLC. for additional work on monument placed in Perth Amboy Cemetery, in (Sec. Perth Amboy War Memorial)

NAME ON MONUMENT: See attachment

SPECIAL INSTRUCTIONS: Inscribed 16 names and 7 gold stars on War Veterans Memorial

INSCRIPTION AS FOLLOWS:

Inscriptions: 16 name @ \$125	\$2,000.00
Inscriptions: 7 Gold stars @ 40.00 \$	280.00
Total:	\$ 2,280.00

Please review, sign and return one copy along with a check payable to "Shevchenko Monuments, LLC," Thank you.

COST: \$ \$2,280.00 TO BE PAID IN FULL, PRIOR TO START OF WORK. WE WILL NOTIFY YOU UPON COMPLETION.

BILL TO:

Business Improvement District
City of Perth Amboy
Attn: Noelia Colon
260 High Street
Perth Amboy, NJ 08861

Email: insert text here

<p>THE PURCHASER AGREES THAT THE ABOVE NAMES (SPELLING AND DATES) ARE CORRECT.</p> <p>(Signed) X _____</p>
--

Sales Representative: Carolyn Maxwell

Today's Date: 11/22/2021

ORDER # BID—2021—0004



PRINT EDITION
AVAILABLE IN OVER
100 LOCATIONS!

P.O. Box 127, Perth Amboy, NJ 08862-0127

www.amboyguardian.com

Carolyn: 732-896-4446 or Katherine: 732-261-2610

amboyguardian@gmail.com

INSERTION ORDER/INVOICE

- ADVERTISER _____ BID—Attn: Noelia Colon _____
- ADDRESS _____ 260 High St. _____
- PHONE _____ 732-442-6421 _____
- _____ Perth Amboy, NJ 08861 _____
- FAX _____
- EMAIL _____ ncolon@perthamboynj.org _____
- WEBSITE _____

- POSITION CHARGE _____
- ONE TIME IN-HOUSE DESIGN FEE _____
- PROOF REQUESTED _____
- PREMIUM WEB FEE _____
- PRE-PAYMENT REQ. BY _____
- FINAL PAYMENT REQ. BY _____

SHORTS

- # TIMES _____
- 1x N/C _____

- SIZE: _____ full page _____
- NUMBER OF TIMES _____ 1 _____
- B&W _____
- COLOR _____ X _____

SPECIAL INSTRUCTIONS:

Attn: Noelia Colon
Special Holiday Rates: Thanksgiving

11/17/21—Winter Wonderland, full page, color, p.3.

DATES OF INSERTION AMOUNT

DATES OF INSERTION	AMOUNT
11/17/2021	\$525.00

REGULAR ADVERTISING RATES: FULL PAYMENT IS DUE UPON SIGNING. A 10% LATE FEE WILL BE APPLIED TO ANY UNPAID AD OVER 30 BUSINESS DAYS ON DATE OF INVOICE. MAKE CHECKS PAYABLE TO THE AMBOY GUARDIAN.

TOTAL AMOUNT _____ \$525.00 _____

I (THE ADVERTISER) AGREE TO PAY FOR THE ABOVE MENTIONED ADVERTISING BY THE DATE SPECIFIED ABOVE. IF ANY PAYMENT OBLIGATION UNDER THIS ACCOUNT IS NOT PAID WHEN DUE, THE INDIVIDUAL SIGNING BELOW PROMISES PERSONALLY TO PAY ALL COSTS OF COLLECTION, INCLUDING REASONABLE ATTORNEY FEES, WHETHER OR NOT A LAWSUIT IS COMMENCED AS PART OF THE COLLECTION PROCESS.

ADVERTISER _____

DATE _____



The City of
PERTH AMBOY
Helmin J. Caba, Honorable Mayor
& City Council Members



The City of Perth Amboy &
Perth Amboy Business Improvement District
present

SMALL BUSINESS SATURDAY

WINTER WONDERLAND



SATURDAY NOVEMBER 27TH 12PM-4PM

RAIN DATE: DECEMBER 4TH

MADISON AVENUE

BETWEEN 5TH STREET AND JEFFERSON STREET



🎵 MUSIC 🎡 INFLATABLE RIDES 🚂 TRACKLESS TRAIN ☕ HOT COCOA 🎁 GIVE-A-WAYS



SHOP SMALL. SHOP LOCAL.
SHOP PERTH AMBOY.
SUPPORT OUR SMALL BUSINESSES!



338 State Street
Perth Amboy, NJ 08861
7328263575
orders@printingcopycenter.com
printingcopycenter.com

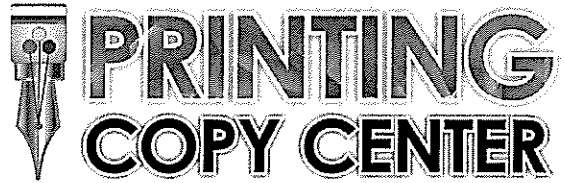

BILL TO
Noelia Colon, BID/UEZ
Executive Director
City of Perth Amboy
Business Improvement District

INVOICE 13861A

DATE 11/24/2021 TERMS Net 15

DUE DATE 12/09/2021

DATE	ACTIVITY	QTY	RATE	AMOUNT
11/23/2021	Cards 3.5 x 2 / Color / Single Sided / 60lb Card Stock	350	0.10	35.00

Thank you for your business.
We hope to see you again!

TOTAL DUE \$35.00

OFFICE: (732) 826-3575 | FAX: (732) 826-3395 |
ORDERS@PRINTINGCOPYCENTER.COM



City of Perth Amboy Employee Expense Report

Employee Name: Noelia Colon Department: BID

Transportation	Mileage	Date	From	To	Total Miles	Rate Per Mile	Amount
		11/16/2021	Perth Amboy	Atlantic City	108.00	\$ 0.560	\$ 60.480
		11/18/2021	Atlantic City	Perth Amboy	108.00	\$ 0.560	\$ 60.480
						\$ 0.560	\$ 0.000
						\$ 0.560	\$ 0.000
Tolls (Attach receipts)							\$ 120.960

Meals	Date	Description (i.e. Lunch at ABC Restaurant)	List Individual Employees, including self	Amount (not to exceed \$25 per employee per day)	

Miscellaneous	Conference Fees	Date	Description	Amount
		11/16/2021	Parking	\$10.00
	11/17/2021	Parking	\$10.00	
	Other Expenses			

Total reimbursement	\$ 140.960
----------------------------	-------------------

*** Please attached ALL related receipts*

Signature: _____ Date: 11/9/2021

Approved Denied

Department Head Signature: _____ Date: _____

Borgata

Thank you for visiting The Borgata and Spa Hotel
Please call 609-317-7596 if you have any questions
or comments

Transfer expires at 6 am

206-555-1212

Ticket: 596370

Spot: A3

Transact: 0000002450562

License/State: E83EMX NJ

Color: White

Make/Mod: Chevrolet

Garage Loc: Borgata

Request Loc: Valet

Arrival Date: 11/17/2021 08:28:33

Trans Date: 11/18/2021 10:27:45

Customer: COLON,

Cashier: Alysia

Park Chrg: 10.00 Casino

Ttl Charge: 10.00 CASH

Amt Tend: 10.00



Borgata

Thank you for visiting The Borgata and Spa Hotel
Please call 609-317-7596 if you have any questions
or comments

Transfer expires at 6 am

206-555-1212

Ticket: 396370

Spot: A3

Transact: 0000002450362

License/State: E83EMX NJ

Color: White

Make/Mod: Chevrolet

Garage Loc: Borgata

Request Loc: Valet

Arrival Date: 11/17/2021 08:28:33

Trans Date: 11/18/2021 10:27:45

Customer: COLON,

Cashier: Alysia

Park Chrg: 10.00 Casino

Ttl Charge: 10.00 CASH

Amt Tend: 10.00



Veronica Pacheco
441 Penn Street,
Perth Amboy, NJ 08861

Invoice

Invoice # 1121
Date: November 30, 2021

BILL TO:
PABID
260 High Street
Perth Amboy, NJ 08861

DESCRIPTION	DATE(S)	UNIT	RATE	AMOUNT
Vendor Services (Clerical)	11/1-11/30	39.50	15.00	\$592.50
			TOTAL	\$592.50



Invoice Number

Account Number

Date Due Page

9893609515

342311378-00001

12/16/21 3 of 6

Overview of Lines

Lines Charges	Page Number	Monthly Charges	Usage and Purchase Charges	Equipment Charges	Surcharges and Other Credits	Taxes, Governmental and Fees	Third-Party Charges (includes Tax)	Total Charges	Voice Plan Usage	Messaging Usage	Data Usage	Voice Roaming	Messaging Roaming	Data Roaming
732-372-8772 Noelia Colon	4	\$70.00	---	---	\$2.55	\$1.30	---	\$73.85	78	158	1.631GB	---	---	---
Total Current Charges		\$70.00	\$0.00	\$0.00	\$2.55	\$1.30	\$0.00	\$73.85						



Summary for Noelia Colon: 732-372-8772

Your Plan

Business Unlimited Smartphone

\$45.00 monthly charge
Unlimited monthly minutes

UNL Text Messaging

Unlimited M2M Text
Unlimited Text Message

Email & Web Unlimited

Unlimited monthly gigabyte

UNL Picture/Video MSG

Unlimited monthly Picture & Video

Monthly Charges

Business Unlimited Smartphone	11/25 - 12/24	45.00
Addl Smartphn Data Access	11/25 - 12/24	25.00
		\$70.00

Have more questions about your charges?
Get details for usage charges at
b2b.verizonwireless.com.

Need-to-Know Information

Bankruptcy Information

If you are or were in bankruptcy, this bill may include amounts for pre-bankruptcy charges. You should not pay pre-bankruptcy amounts; they are for your information only. In the event Verizon receives notice of a bankruptcy filing, pre-bankruptcy charges will be adjusted in future invoices. Mail bankruptcy-related correspondence to 500 Technology Drive, Suite 550, Weldon Spring, MO 63304.

Explanation of Surcharges

Surcharges include (i) a Regulatory Charge (which helps defray various government charges we pay including government number administration and license fees); (ii) a Federal Universal Service Charge (and, if applicable, a State Universal Service Charge) to recover charges imposed on us by the government to support universal service; and (iii) an Administrative Charge, which helps defray certain expenses we incur, including: charges we, or our agents, pay local telephone companies for delivering calls from our customers to their customers; fees and assessments on our network facilities and services; property taxes; and the costs we incur responding to regulatory obligations. **Please note that these are Verizon Wireless charges, not taxes. These charges, and what's included, are subject to change from time to time.**

More On Wireless Taxes And Surcharges

Your total charges for this month's bill cycle are \$73.85.

This includes charges for one or more bundled Verizon service plans that include voice, messaging, data, or other services for which you pay a monthly plan charge.

This bill cycle, your fixed monthly plan charges were \$45.00 (before applying any discounts or credits, and excluding other charges such as overage, late payment, taxes, Verizon surcharges, and equipment).

To accurately bill taxes and Verizon surcharges, we regularly look at past network usage by you and other customers with similar plans to allocate this fixed monthly plan charge among the services included in the bundle.

In this bill cycle, we have allocated this amount as follows: \$2.89 for voice, \$0.58 for messaging, \$41.53 for data, and \$0.00 for other services.

For more information, please go to vzw.com/taxesandsurcharges.

Returned Payments

If you pay your wireless bill by check and your check is returned by your bank for insufficient funds, Verizon Wireless may resubmit your check to your bank for payment from your checking account.

Credit Adjustments

A recent bill contained incorrect charges or credits. The corrections will be reflected in this bill. We apologize for any inconvenience.

Device Payment Final Payment

We have received the final payment for certain Device Payment Agreement(s). Please log into sso.verizonenterprise.com and navigate to the View Statement in the Billing Section for more details. If your final payment is insufficient or rejected, you will be billed for the total remaining balance on a subsequent bill.

Piasecki & Whitelaw, LLC
 Attorneys At Law
 239 U.S. 22, Suite 303
 Green Brook NJ 08812
 (732) 560-1616

 TIN 86-1153991

Business Imporvement District
 260 High Street
 Perth Amboy NJ 08861

Page: 1
 12/05/2021
 Our File: 1930-00000Q
 Statement No: 73417

Attn: Noelia Colon

BID General Matters

For professional services rendered:

			Rate	Hours	
04/07/2021	CEP	Telephone conference regarding history of BID/City relationship.	250.00	0.40	100.00
04/13/2021	CEP	Correspondence to NC regarding BID/City employment relationship.	250.00	0.10	25.00
04/21/2021	CEP	Review of 2014 Agreement and other documentation - Correspondence to NC in review.	250.00	1.00	250.00
05/25/2021	CEP	Correspondence to/from NC.	250.00	0.10	25.00
06/22/2021	CEP	Telephone conference with NC, including preparation, regarding employment factors.	250.00	0.80	200.00
	CEP	Correspondence to/from NC - confirming letter.	250.00	0.20	50.00
07/02/2021	CEP	Draft BID memo foundation.	250.00	3.50	875.00
07/22/2021	CEP	Correspondence to/from NC regarding W2 progress.	250.00	0.20	50.00
08/17/2021	CEP	Correspondence to/from NC regarding elements of the claim.	250.00	0.10	25.00
10/18/2021	CEP	Telephone conference with NC regarding employment summary and history.	250.00	0.20	50.00
	CEP	Telephone conference with NC regarding BID Agreement.	250.00	0.10	25.00
10/21/2021	CEP	Review of NPP resolutions and draft contract including redline.	250.00	1.30	325.00
10/22/2021	CEP	Review NC response and draft reply regarding final agreement between BID and City	250.00	0.40	100.00
		For Current Services Rendered		8.40	2,100.00

Recapitulation

<u>Timekeeper</u>	<u>Hours</u>	<u>Rate</u>	<u>Total</u>
Chris E. Piasecki	8.40	\$250.00	\$2,100.00

Business Improvement District

BID General Matters

Page: 2
12/05/2021
Our File: 1930-00000Q
Statement No: 73417

Total Current Fees and Expenses

2,100.00

Balance Due

\$2,100.00

Final Statement Run Totals 12/05/2021

Statements Printed:	1
Hours:	8.40
Fees:	2,100.00



Pashman Stein Walder Hayden
Court Plaza South
21 Main Street, Suite 200
Hackensack, NJ 07601
(201) 488-8200
Tax I.D. 22-3384189

Noelia Colon, Executive Director
Downtown Perth Amboy Business Improvement District, Inc.
260 High Street
Perth Amboy, NJ 08861

December 6, 2021
Invoice #99925
File Number: 29505-001

RE: General

PROFESSIONAL SERVICES

Date	Attorney	Description	Hours
11/01/2021	DGuada	Revised proposed agreement with Key Marketing.	1.40
11/02/2021	DGuada	Review and edits and comments to management letter.	0.70
11/08/2021	DGuada	Advice and counsel; letter to attorney for Silber.	1.00
11/10/2021	DGuada	Review of law and case law; advice and counsel to By-Laws Committee; drafted legal memo; comparison of settlement agreement sent by Leurs; follow up re Villafane case.	1.50
11/12/2021	DGuada	Advice and counsel; comparison of Villafane Settlement to our Version.	1.00
11/15/2021	DGuada	Reviewed and compared signed SA sent by Stephanie's counsel to ensure no inordinate changes; sent same for signature; advice and counsel; conference with City and counsel for City and BID representatives.	1.00
	DGuada	Conference with Mayor and counsel and chief of staff and Noelia; advice and counsel to BID before and after.	1.30
11/23/2021	DGuada	Travel to and meeting with By-Laws Committee; Advice and counsel finalizing settlement in Stephanie Villafane case; consultation with 2 govt lawyer partners at PS re advice to By-Laws Committee.	3.80
		Total	11.70

DISBURSEMENTS

Description	Amount
UPS-1018899724	\$15.38
Total	\$15.38

PROFESSIONAL SERVICES SUMMARY

Attorney	Description	Hours	Rate	Amount
DGuada	Guadalupe, Daniel R.	11.70	\$250.00	\$2,925.00
Total		11.70		\$2,925.00

Total Fees & Disbursements	\$2,940.38
Previous balance	\$8,037.50
11/29/2021 Payment - Thank you, Check # 1181	(\$3,612.50)
11/29/2021 Payment - Thank you, Check # 1182	(\$2,350.00)
11/29/2021 Payment - Thank you, Check # 1183	(\$2,075.00)
Balance due upon receipt	\$2,940.38

Welcome to Dunkin'
Store #: 337734
482 Smith St
Perth Amboy, NJ 08861
(732) 826-0884
210004 Irribette

CHK 9136
11/27/2021 10:52 AM

Eat In

15 Box Orig Hot Choc 344.85
Visa \$344.85

*****2942

Tran Type : Purchase

Entry Mode : INSERTED

Auth Code : 392365

AID: A0000000031010

No Signature Required

I agree to pay the above total

amount according to the card

issuer

(merchant agreement if credit
voucher)

Subtotal \$344.85

Payment \$344.85

Change Due \$0.00

DD Perks(R) Prior Points Balance 180

DD Perks Points Earned 1725

DD Perks Reward Issued -1800

DD Perks Points Balance 105

SupportCode 34591178

CONGRATULATIONS!

You've earned a DD Perks

Free Beverage reward!

Find it in your Dunkin' App or sign
in to your account at ddperks.com.

----- Check Closed -----

11/27/2021 10:53 AM

Donut forget to tell us about

today's visit! Talk to us at

www.DunkinRunsOnYou.com

within 3 days and receive a

FREE CLASSIC DONUT

on your next visit when you

purchase a Medium or Larger Beverage

See restrictions on dunkindonuts.com

Survey Code: 13601-37734-1011-2717

Additional Discounts Will Not Be

Applied to Promotional Offers

Small
Business
Saturday
11/27/2021

1

Welcome to Dunkin'
Store #: 838764
557 Fayette St
Perth Amboy, NJ 08862
(732) 442-8345

23580 A Lydia

CF-C 15050
11/27/2021 10:42 AM

Enter: Item
12 3oz Orig Hot Choc 275.88
TAX \$275.88
*****E252

Trans Type : Purchase
Entry Mode : INTEREC
Auth Code : 261762
VCS: CIBIT
ACD: 4000000021 010
No Signature Required
I agree to pay the above total
amount according to the card
issuer
(merchant agreement if credit
voucher)

Subtotal \$275.88
Payment \$275.88
Change Due \$0.00

DD Perks (E) Prior Points Balance 0
DD Perks Points Earned 1300
DD Perks Reward Issued -1200
DD Perks Points Balance 100

Support Code 34501179

CONGRATULATIONS!
You've earned a DD Perks
Free Beverage reward!
Find it in your Dunkin' App or sign
in to your account at ddperks.com.

----- Check Closed -----
11/27/2021 10:43 AM

Donut forget to tell us about
today's visit. Talk to us at
www.DunkinRunsOnYou.com
within 3 days and receive a
FREE CLASSIC DONUT
on your next visit when you
purchase a Medium or Larger Beverage

See restrictions on dunkindonuts.com

*Small Business
Saturday #2
11/27/2021*

DOWNTOWN

NEW JERSEY

Robert Zuckerman
President

Jay S. Kruse
Vice President

Jonathon Tyler
Vice President

Vanessa Quijano
Treasurer

Sherry Cronin
Secretary

Nancy Adams

Susan Adelizzi-Schmidt

Gabe Bailor

Chris Bernardo

Jef Buehler

Michael Darcy

Julie Doran

Deborah Hoffman

Robert S. Goldsmith, Esq

Stuart Koperweis

Beth Lippman

Emily Manz

Elayne McClaine

Robert Peluso

Maggie Peters

Michael Redpath

Michelle Richardson

Donald Sammet

Stephen A. Santola

Pamela Stefanek

Tom Strowe

Debra Tantleff

November 22, 2021

Noelia Colon
Perth Amboy Business Improvement District
260 High Street
Perth Amboy, NJ 08861

Dear Noelia,

We know it's been rough for downtowns this past year. Downtown New Jersey has been busy keeping up with the changing landscape for main streets and downtown communities during the public health crisis. Our ability to continue to advocate for New Jersey's downtowns during these especially challenging times depends on member support.

You will find a report about our efforts over the past year included in this mailing. We hope you will read it and see the value in **renewing your membership**.

MORE MEMBERSHIP OPTIONS!

We've heard from members and partners that you'd like more flexible pricing options that better match your budgetary capacity, and/or provide enhanced opportunities to sponsor DNJ's efforts. Here's what we came up with:

1. **Scaled Non-Profit Rates:** We are now offering a range of rates for our non-profit partners that scale with their organizational budget. We think this will make it easier for organizations to take advantage of member benefits at a comfortable price point.
2. **Member Sponsor Rates:** For organizations looking to provide extra support to DNJ, we are now packaging membership with sponsorship opportunities that will give you more exposure on our website, in the newsletter, and during the conference and other events. Check out the information sheet on the back of the membership form for more information about member sponsor options.

DNJ members help to make our work possible. Please support Downtown New Jersey by renewing your membership today. We look forward to working with you and wish you a happy, healthy summer.

Cordially,

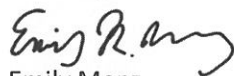

Emily Manz
Membership Committee Chair



Courtenay D. Mercer, PP, AICP
Executive Director

Courtenay D. Mercer, PP, AICP
Executive Director

Downtown New Jersey

ANNUAL REPORT

2020-2021

EDUCATIONAL PROGRAMMING

The COVID pandemic made us all re-think our priorities and shift programming to best serve our constituencies. After the public health emergency was announced, DNJ immediately began offering virtual opportunities for downtown managers, economic development professionals, and public officials to exchange information and ideas about best practices related to COVID response and downtown economic development.



- 30 FORUMS
- 1k+ ATTENDEES
- 100% FREE TO MEMBERS

NJ DOWNTOWN CONFERENCE

- 1 VIRTUAL EVENT
- 1 KEYNOTE
- 3 DAYS
- 5 PANELS
- 150 ATTENDEES
- 2 NETWORKING SESSIONS
- 1 VIRTUAL TOUR & COCKTAIL HOUR



DOWNTOWN

NEW JERSEY

ADVOCACY

As always, DNJ provided detailed policy and legislative updates throughout the year; but we are also part of several coalitions made up of mayors, businesses, and other allied organizations to advocating for policies that support NJ's downtowns.



COALITION TO OPPOSE ACS A1571/A1576

RECOGNITION

DNJ likes to show off the great work of our members and partners!



- 8 AWARDEES
- 10 HONORABLE MENTIONS

MEMBER SPOTLIGHT

- ARTERIAL
- CDS
- INVEST NEWARK
- VERONA
- WESTFIELD
- + SEVERAL SPECIAL EDITION ARTICLES HIGHLIGHTING THE MANY MEMBERS & PARTNERS DOING GREAT WORK DURING COVID

www.DOWNTOWNNJ.com

✉ info@downtownnj.com

☎ 201472.0356

📘 @DowntownNewJersey

🐦 @DowntownNJ



N E W J E R S E Y

Membership Dues for January 2022 to December 2022

Thank you for renewing your Downtown New Jersey membership!

Please update below, as necessary:

Noelia Colon _____

Perth Amboy Business Improvement Distirct _____

260 High Street _____

Perth Amboy, NJ 08861 _____

ncolon@perthamboynj.org _____

732-442-6421 _____

www.perthamboynj.org _____

www.facebook.com/PerthAmboyBID _____

Twitter: _____

Membership Type (check one)

Amount Enclosed: \$ _____

Member Sponsor (see reverse)		Non-Profit (based on budget)	
Downtown Benefactor	\$4,000	Over \$500k	\$500
Downtown Advocate	\$3,000	\$300k-\$499k	\$400
Downtown Ally	\$2,000	\$200k-\$299k	\$300
Corporate/Institutional (11+ employees)	\$1,000	\$100k-\$199k	\$200
Business/Professional (3-10 employees)	\$500	Under \$100k	\$100
Micro Business (2 or fewer employees)	\$350	Individual	\$100
Government	\$300	Student	\$25

Please make check payable and mail payment and form to:

Downtown New Jersey, Inc.
344 Grove Street, Suite 251
Jersey City, NJ 07302

You can also join online at www.downtownnj.com/membership
Questions? Email info@downtownnj.com or call 201-472-0356.

DOWNTOWN

NEW JERSEY

Member Sponsorship Options

Downtown Benefactor (\$4,000)

- 1 year membership
- Exclusive sponsorship of one (1) Downtown NJ Forum, Roundtable, or equivalent Event
- One (1) year advertising on DNJ homepage
- One (1) year advertising on DNJ member page
- One (1) year advertising on DNJ Newsletter
- Title Sponsorship at DNJ Annual Conference
 - Pre-event messaging with five (5) dedicated social media posts
 - Keynote sponsorship
 - Clickable banner ad on conference splash page
 - Exhibitor space (in-person day)/breakout room (virtual day)
 - Logo on opening slide before each session
 - Static exhibitor webpage page
 - Eight (8) event registrations

Downtown Advocate (\$3,000)

- 1 year membership
- Exclusive sponsorship of one (1) Downtown NJ Forum, Roundtable, or equivalent Event
- One (1) year advertising on DNJ member page
- Six (6) months advertising on DNJ Newsletter
- Session Sponsorship at DNJ Annual Conference
 - Pre-event messaging with three (3) dedicated social media posts
 - Single session sponsorship
 - Clickable sidebar ad or logo on conference splash page
 - Exhibitor space (in-person day)/breakout room (virtual day)
 - Static exhibitor webpage
 - Five (5) event registrations

Downtown Ally (\$2,000)

- 1 year membership
- Sponsorship of one (1) Downtown NJ Forum, Roundtable, or equivalent Event
- One (1) year advertising on DNJ member page
- Six (6) months advertising on DNJ Newsletter
- Ally Sponsorship at DNJ Annual Conference
 - Pre-event messaging with one (1) dedicated social media post
 - Clickable logo on conference splash page
 - Exhibitor space (in-person day)/breakout room (virtual day)
 - Static exhibitor webpage
 - Three (3) event registrations

www.DOWNTOWNNJ.com

✉ nfo@downtownnj.com

☎ 201.472.0356

📘 @DowntownNewJersey

🐦 @DowntownNJ



891 State St., Perth Amboy NJ 08861
 P. (732) 442-8080 • F. (732) 442-3113

QUOTE

Location Information: 260 High Street Perth Amboy, NJ 08861	Client Information: City of Perth Amboy Address: 260 High Street Perth Amboy, NJ 08861 Contact: Noelia (732) 442-6421	Quote Date: 11/24/2021 Project #: Quote #: 10744 Questions? 732-213-4151 Infosales.nc@gmail.com
Requested Amount to Start Production: \$397.25		

DESCRIPTION:

4- 10'-0" X 4'-0" Decals to Update Information On \$794.50
 "Small Business Saturday" Banner

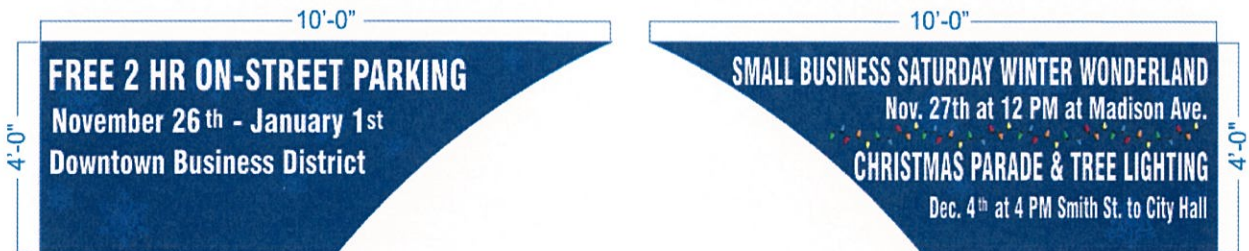

TOTAL PROJECT COST: \$794.50

Price includes all materials, labor, and equipment to design, produce this project.

Price does not include tax.

*Please provide tax exempt forms.

Note: The installation is not included in price.

Public works crew normally manages the installation.

Payment Options

Requested Amount to Start Production: \$397.25

Balance COD: \$397.25

1st Payment: _____ 2nd Payment: _____

THANK YOU FOR DOING BUSINESS WITH US!



Simplifying Media. Delivering Results.
PART OF THE USA TODAY NETWORK

ACCOUNT NAME		ACCOUNT #	PAGE #
Perth Amboy Business Improvement District		423673	1 of 1
STATEMENT #	BILLING PERIOD	PAYMENT DUE DATE	
0004206633	Oct 1- Oct 31, 2021	November 20, 2021	
PREPAY (Memo Info)	UNAPPLIED (included in amt due)	TOTAL AMOUNT DUE	
\$0.00	\$0.00	\$22.36	
BILLING ACCOUNT NAME AND ADDRESS		BILLING INQUIRIES/ADDRESS CHANGES	FEDERAL ID
Perth Amboy Business Improvement District 260 High St. Perth Amboy, NJ 08861-4451 		1-877-736-7612 or smb@ccc.gannett.com	47-2390983
<p>Terms and Conditions: Past due accounts are subject to interest at the rate of 18% per annum or the maximum legal rate (whichever is less). Advertiser claims for a credit related to rates incorrectly invoiced or paid must be submitted in writing to Publisher within 30 days of the invoice date or the claim will be waived. Any credit towards future advertising must be used within 30 days of issuance or the credit will be forfeited. All funds payable in US dollars.</p>			

00004236730000000000000042066330000223611717

To sign-up for E-mailed invoices and online payments please contact abgspecial@gannett.com. Previous account number: **000002890**.

Date	Description	Amount
10/1/21	Balance Forward	\$22.36

PLEASE DETACH AND RETURN THIS PORTION WITH YOUR PAYMENT



Simplifying Media. Delivering Results.
PART OF THE USA TODAY NETWORK

ACCOUNT NAME		PAYMENT DUE DATE		AMOUNT PAID		
Perth Amboy Business Improvement District		November 20, 2021				
ACCOUNT NUMBER		STATEMENT NUMBER				
423673		0004206633				
CURRENT DUE	30 DAYS PAST DUE	60 DAYS PAST DUE	90 DAYS PAST DUE	120+ DAYS PAST DUE	UNAPPLIED PAYMENTS	TOTAL AMOUNT DUE
\$0.00	\$0.00	\$0.00	\$0.00	\$22.36	\$0.00	\$22.36

REMITTANCE ADDRESS (Include Account# & Invoice# on check) Gannett New Jersey Newspapers PO BOX 677599 Dallas, TX 75267-7599	TO PAY WITH CREDIT CARD PLEASE FILL OUT BELOW: <input type="checkbox"/> VISA <input type="checkbox"/> MASTERCARD <input type="checkbox"/> DISCOVER <input type="checkbox"/> AMEX Card Number _____ Exp Date / / CVV Code _____ Signature _____ Date _____					
---	--	--	--	--	--	--

00004236730000000000000042066330000223611717

December 9, 2021

Public Relations Services

Overview of the Assignment

Essential PR prepared a Media Advisory for the 2021 *Perth Amboy Eats: Food Tour*.

The company also distributed the Perth Amboy Eats: Food Toru news release and media advisory to news media list that included the following outlets:

- Spanish-language news outlets including Ahora News, Americano Newspapers, El Especialito, Reporte Hispano, Latinos Unidos de Nueva Jersey, Luso-Americano Univision Channel 41, Telemundo NY/NJ and more
- Central New Jersey Media including Home News Tribune/MYCentralJersey.com, N.J. Press Media (news service), The Star Ledger (Middlesex bureau and food journalists), Amboy Guardian, Perth Amboy Now, Asbury Park Press (food reporter), Associated Press (Newark correspondent), New Jersey Patch, Middlesex Daily Voice (online news source) and more
- Broadcast and cable news including News 12, N.J. 101.5, WMBC-TV, WNBC-TV (N.J. reporter), WABC-TV (N.J. reporter), WBGO-FM, NJ-PBS, and WCBS-TV plus Fox 5 N.Y. (which includes WWOR-TV).
- Essential PR also provided the BID's Executive Director with an updated media list.

Invoice

- Essential PR agreed to draft the Perth Amboy Eats: Food Media Advisory and distribute the news release and advisory. The fee is \$250.

Please make the payment to Essential Communications, LLC.

Note: Thank you for the opportunity to serve and assist the Perth Amboy BID, the community's businesses and the City of Perth Amboy. Essential PR is grateful to be associated with the BID and its Board of Directors. The organization and its allies continue to transform and enhance the city's downtown business district, while providing many useful serves to local companies.

Essential PR
29 Highpoint
Cedar Grove, New Jersey 07009
973.509.3431 or 973-768-2425
robertrinklin@outlook.com

Season's Greetings

**LAW OFFICES OF
Kenneth L. Gonzalez
& Associates, LLC**
Oficina de Abogados

Merry Christmas

Serving the Middlesex County
& Surrounding Areas
klg.office@lawyergonzalez.com

Phone: 732-442-2500
Fax: 732-442-0114
283 High Street
Perth Amboy NJ 08861

Friends of the Perth Amboy Library Book Sale Return!

PERTH AMBOY - The Friends of the Perth Amboy Free Public Library are once again having a book sale on Saturday January 8th & 22nd from 1 p.m. until 3 p.m. at the Brighton Avenue Community Center at the corner of Brighton Avenue and Sadowski Parkway in Perth Amboy. I know many people have been starving for reading material for these long months we were at home. We will be wearing masks and providing hand sanitizer and bags if needed. We also insist that anyone coming to peruse our collection also wear a mask as mandated by the State of NJ. Paperbacks are \$.50, hardcovers are \$1, \$5 for a bag full, no limit to size of bag except no lawn or garbage bags. We have best sellers by popular authors that are like new. The money we raise goes to support the library with providing programs, promoting literacy or to provide funds to the library with their needs beyond their budget. We look forward to your visit.

For more information email us at friendsofperthamboylibrary@gmail.com, or call us at 201-381-1903 and like us on Facebook. Dealers are welcome. At this time, we are not accepting donations of books.

DANIEL F. GONZALEZ, ESQ, LLC
ATTORNEY AT LAW

602 STATE ST, 2ND FLOOR PERTH AMBOY, NJ 08861

**Merry Christmas &
A Happy New Year**

TEL: (732) 697-1134 / FAX: (732) 697-1135
<https://www.eliasandgonzalez.com/>

Season's Greetings
"He who has a garden and a library wants for nothing"
-Cicero-

Friend Your Library

Perth Amboy Free Public Library
106 Jefferson Street
Perth Amboy, NJ 08861
Phone: 732-826-2600

www.folperthamboy.com
friendsofperthamboylibrary@gmail.com

Ana Maria Zevallos/Skrocki
HOME for FUNERALS
732-826-1321
469 State Street-Perth Amboy

During Your Time of Need.....

- Traditional Funerals
- Cremation Services
- Pre-Planned Funeral Services
- Shipment to Foreign Locations
- Public Assistance Accepted

Family Owned and Operated
Available 24 Hours / Se Habla Español

Merry Christmas
From Our Family to yours!

Ana M. Zevallos
Senior Director
N.J. License # 4192

Merry Christmas
R & S GLASS & MIRROR INC.
BOB CHAPMAN
• Auto • Residential
• Commercial • Industrial

414 Amboy Ave.
Perth Amboy NJ, 08861
(732) 442-5433
Board up service (732) 429-9072

Happy Holidays
FROM THE PERTH AMBOY BUSINESS IMPROVEMENT DISTRICT

SMALL BUSINESS GRAND OPENINGS
DOWNTOWN IMPROVEMENTS & BEAUTIFICATION
'MORNING GLORY' DOWNTOWN MURAL EXPANSION
EAT · DRINK · VISIT
ONLINE PROMO FOR EATERIES | WWW.PERTHAMBOYEATS.COM
FINK PARK FALL POP-UP ART INSTALLATION

BID BUSINESS MEETINGS | FOR EDUCATION & RESOURCES
SUPPORTING EATERIES & LOCAL VETERAN INITIATIVE

Merry Christmas and a Happy New Year to All Our Customers
Feliz Navidad & Feliz Año Nuevo a Todos Nuestros Clientes
From

QUISQUEYA MEAT MARKET
FREE DELIVERY!
249 Madison Ave.
Perth Amboy, NJ, 08861

Phone: 732-826-8926 Fax: 732-826-0789
We accept credit cards, Wic, Food Stamps

'Tis the season for us to tell you how much you mean to us. As we reflect on this past year, we've seen nothing but strength and perseverance demonstrated by our creative and hard-working business community.

It has been a pleasure serving you this past year. We will continue to work diligently and in good faith to deliver our best, to help meet your needs and to support you in achieving remarkable growth and prosperity.

On behalf of the BID board, we want to thank you, the City of Perth Amboy's governing body and our co-partnership with the Neighborhood Preservation Program (OECD team) that helped us make these beautification projects possible. Together, we will accomplish wonderful things in 2022. Merry Christmas!

Our warmest thoughts and best wishes for a blessed holiday and a joyous New Year-- From All of Us at the Perth Amboy Business Improvement District!

Perth Amboy Business Improvement District
260 High Street
(732)-442-6421

SHOP SMALL, SHOP LOCAL, SHOP PERTH AMBOY, SUPPORT OUR SMALL BUSINESSES!

The City of PERTH AMBOY
Historic City of Perth Amboy
& City Council Members

BROADWAY
Ange
@broadwayange124
Renee Banks
Mon-Sat
11am-5pm
124 South Broadway
South Amboy, NJ 08879
(732) 313-7669

Merry Christmas



Small Business Saturday
Disposable cups (Qty: 100)

11/24/2021

Welcome to ShopRite
of PERTH AMBOY

Open - 24 Hours - Everyday

11/24/21 02:05pm S156 R71 T132 C71

* Regular Items *

8 @ 1.79
DART SEL 8.5 FOAM 14.32 T
Valued Customer 47109840444
TAX 0.47
**** BALANCE 14.79

***** Transaction Record *****
ShopRite of PERTH AMBOY, NJ
Store # 156
Terminal: 71 Operator: 71
11/24/21 02:06pm 132
Acct#: *****2942 CHIP

Purchase: \$ 14.79

RESPONSE CODE: APPROVED
APPROVAL CODE: 584082
PREPAID CARD BALANCE: 0.00

VISA CARD 14.79
CHANGE 0.00
TOTAL NUMBER OF ITEMS SOLD = 8
11/24/21 02:07pm 156 71 132 71

Present your card with every order
and save with Price Plus discounts!

Questions or comments?
Contact us at 1-800-SHOPRITE or
on the web at www.shoprite.com

YOUR HOLIDAY POINTS: \$ 297.30 of \$400
QUALIFY & REDEEM 10/17 - 11/25/21

* HOW WAS YOUR VISIT TODAY? *

Please take our survey within
7 days for a chance to win
\$500 in ShopRite Gift Cards.
Visit MyShopRiteExperience.com
Keep this receipt handy!
You will need it
to begin the survey.
Thank you for your feedback!



YOUR CASHIER TODAY: SCOT 71

* Store Phone Number (732) 442-1717 *
** THANK YOU FOR SHOPPING WITH US!! *
Your Store Manager is JR Mercado

RESOLUTION ADOPTING THE 2022 PERTH AMBOY BUSINESS IMPROVEMENT DISTRICT BUDGET FOR JANUARY 1, 2022 TO DECEMBER 31, 2022

WHEREAS, a public hearing was held on November 8, 2021 and November 22, 2021 on the 2022 Budget of the Perth Amboy Business Improvement District, Inc. approved by City Council Resolution R-544-10/21 on October 27, 2021; and

WHEREAS, all the conditions and requirements of N.J.S.A.40:56:84f(1) have been met; and

WHEREAS, said budget has been read by title pursuant to N.J.S.A. 40:56:84f(2).

NOW, THREFORE, IT IS HEREBY RESOLVED BY THE COUNCIL OF THE CITY OF PERTH AMBOY:

That the budget of the Perth Amboy Business Improvement District for January 1, 2022 to December 31, 2022, a copy which is attached hereto and incorporated herein by reference, is hereby adopted.

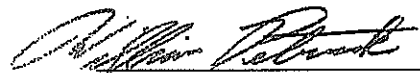

WILLIAM A. PETRICK
Council President



VICTORIA ANN KUPSCH
City Clerk

Dated: November 22, 2021

APPROVED AS TO FORM:

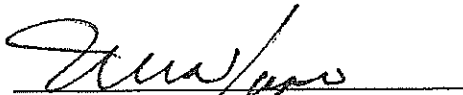

WILLIAM W. NORTHGRAVE
Director of Law

PERTH AMBOY BUSINESS IMPROVEMENT DISTRICT
CITY HALL
260 High Street
Perth Amboy, NJ 08861
(732) 442-6421

PUBLIC NOTICE
CITY OF PERTH AMBOY, NEW JERSEY

To: Home News Tribune Susan Russell - srussell@gannettnj.com
Home News Tribune Susan Loyer – sloyer@gannettnj.com
Gannet NJ GanLegPubNotices@gannett.com
The Star Ledger njadvancemedia@nj.com
The Star Ledger legalads@njadvancemedia.com
The Amboy Guardian amboyguardian@gmail.com
Dave Garb, Channel 34 davegarb@paps.net

From: Barry Rosengarten, Chairman

Date: December xx, 2021

PERTH AMBOY BUSINESS IMPROVEMENT DISTRICT
NOTICE

The Perth Amboy Business Improvement District (“BID”) hereby announces its regular meeting schedule for 2022 in accordance with the provisions of the “Open Public Meetings Act”, N.J.S.A. 10:4-18.

1. The regular meetings of the BID are to be held in the Council Chamber, Perth Amboy City Hall, 260 High Street, Perth Amboy, New Jersey at **4:00 pm on Tuesdays**, on the dates set forth below:

January 11, 2022	February 08, 2022	
March 08, 2022	April 12, 2022	May 10, 2022
June 14, 2022	July 12, 2022	September 13, 2022
October 11, 2022	November 08, 2022	December 13, 2022

Important: Location is subject to change, due to the ongoing impacts of COVID-19 and potential State order and regulation changes. Meetings may be held in an alternative location or remotely via Zoom online conference. Notification of change(s) will be posted on www.perthamboynj.org in accordance to OPMA. Additionally, the BID will not hold a meeting in the Month of August.

cc: Hon. Helmin J. Caba, Mayor
Michael E. Greene, Business Administrator
Victoria Kupsch, City Clerk
BID Board
Bulletin Board

GILL & CHAMAS, L.L.C.

Mailing Address:

P.O. Box 760
Woodbridge, New Jersey 07095

Physical Address:

655 Florida Grove Road
Woodbridge, New Jersey 07095
732-324-7600
732-324-7606 Fax

Website: www.GillandChamas.com



RAYMOND A. GILL, JR. *†
Certified with National Board of Trial Advocacy
PETER CHAMAS *†
JAMES PAGLIUCA
PAUL K. CALIENDO *†
DAVID H. LANDE *†‡
ROBERT J. ADINOLFI
ERROLL J. HAYTHORN *
MAX J. STAGLIANO °

Certified by the Supreme Court of New Jersey as a Civil Trial Attorney †
Certified by the Supreme Court of New Jersey as a Workers' Compensation Attorney ‡
Member of NJ and VA Bars *
Member of NJ and PA Bars °

E-Mail: MStagliano@gillandchamas.com

RICHARD T. SMITH *
WILLIAM A. BOCK
MARK J. JAFFE *
ANDREW L. CHAMBARRY
RAYMOND A. GILL, III
ROBERT E. TAYLOR
WALTER DANA VENNEMAN *†
KAELEIGH P. CHRISTIE

Member of NJ and NY Bars *
Member of NJ and MA Bars °

ROBERT LEIGHT
1999-2010

October 25, 2021

All via reg. & Certified Mail, R.R.R.

City of Perth Amboy
260 High Street
Perth Amboy, NJ 08861

✓ Perth Amboy Business Improvement District
260 High Street
Perth Amboy, NJ 08861

City of Perth Amboy
Department of Public Works
599 Fayette Street
Perth Amboy, NJ 08861

City of Perth Amboy
Code Enforcement Department
375 New Brunswick Avenue
Perth Amboy, NJ 08861

City of Perth Amboy
Engineering Dept.
260 High Street
Perth Amboy, NJ 08861

Middlesex County Board of Chosen Freeholders
75 Bayard Street
New Brunswick, NJ 08901

NOV 1 2021 PM 5:00
REC'D PERSONNEL

State of New Jersey
Attn: Risk Management
20 West 8th Street, 6th Floor
Trenton, NJ 08625

John Doe Departments of the City of Perth Amboy (responsible for Sidewalk
Construction & Repairs, & Enforcement of Chapter 386)

John Doe Public Employees of the City of Perth Amboy (responsible for Sidewalk
Construction & Repairs & Enforcement of Chapter 386)

RE: Silber vs. City of Perth Amboy, et al.

NOTICE OF TORT CLAIM

(N.J.S.A. 59:1-1 et seq.)

1. **NAME AND POST OFFICE ADDRESS OF CLAIMANT:**

Alan Silber & Sonia Silber (per quod)

2. **POST OFFICE ADDRESS TO WHICH THE PERSON PRESENTING
THE CLAIM DESIRES NOTICES TO BE SENT:**

Max J. Stagliano, Esq.
Gill & Chamas, LLC
655 Florida Grove Road
Woodbridge, NJ 07095

3. **DATE, PLACE AND OTHER CIRCUMSTANCES OF THE
OCCURRENCE OR TRANSACTION WHICH GAVE RISE TO THE
CLAIM ASSERTED:**

On or about September 25, 2021, claimant was caused to fall on a defective sidewalk where dangerous bolts, anchors, or metal objects jutted or protruded above a tree grate on the sidewalk surface at or close to the location of 139-141 Smith St., abutting the front of the Fink's Department Store &/or Metro by T-Mobile from what appears to be removal of T-Mobile advertising signs, in the City of Perth Amboy, New Jersey causing serious and permanent personal injuries and substantial loss of bodily function, in violation of N.J.S.A. 59:4-2, et seq.

4. **DESCRIPTION OF THE INJURY, DAMAGE OR LOSS INCURRED SO FAR AS IS KNOWN AT THIS TIME:**

Claimant sustained a fractured rib, closed head injury, and low back injuries.

5. **NAMES OF PUBLIC ENTITY OR EMPLOYEES CAUSING THE INJURY, DAMAGE OR LOSS:**

City of Perth Amboy; City of Perth Amboy Department of Public Works; City of Perth Amboy Code Enforcement Department; City of Perth Amboy, Engineering Dept.; Perth Amboy Business Improvement District; Middlesex County Board of Chosen Freeholders; State of New Jersey; John Doe Departments of the City of Perth Amboy (responsible for Sidewalk Construction & Repairs, & Enforcement of Chapter 386); John Doe Public Employees of the City of Perth Amboy (responsible for Sidewalk Construction & Repairs & Enforcement of Chapter 386)

6. **ESTIMATED AMOUNT OF PRESENT AND PROSPECTIVE INJURY, PROPERTY DAMAGE AND LOSS:**

\$1,000,000

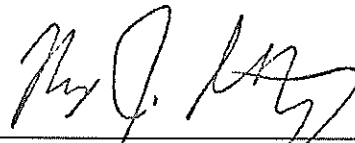

MAX J. STAGLIANO, ESQ.

November 8, 2021

Via UPS 2-day

Max J. Stagliano, Esq.
Gill & Chamas, LLC
655 Florida Grove Road
Woodbridge, N.J. 07095

**Re: Silber v. City of Perth Amboy et al.
Notice of Tort Claim dated October 25, 2021**

Dear Mr. Stagliano:

This firm represents the Downtown Perth Amboy Business Improvement District, Inc. (“the BID”) in the above matter.

I am in receipt of your “Notice of Tort Claim” dated October 25, 2021 regarding Mr. Alan Silber and Ms. Sonia Silber who claim certain damages and injuries allegedly as a result of an alleged sidewalk “condition” at 139-141 Smith Street, Perth Amboy, New Jersey (“the Property”).

Please note that the BID is not a public agency and is not subject to the New Jersey Tort Claims Act. The BID is a non-profit corporation incorporated in New Jersey in 1991 under the Non-Profit Business Corporation Act, N.J.S.A. 15A: 5-20 et seq. In 1995, by Ordinance No. 776-95, the City created a Special Improvement District under the Special Improvement District Act, N.J.S.A. 40:56-65 to 89 and designated the BID as the *corporation* to manage the improvement district.

Please also note that the BID does not own or lease the Property or have any obligation to maintain it or its sidewalk. It had no involvement whatsoever with said sidewalk or Property. Similarly, as a matter of law, the BID does not have any legal responsibility to maintain the sidewalk referenced in your Notice. See below Ordinance 386-14 making the owners of the lands where the sidewalks are located solely responsible for their safe condition:

John J. Kane, Esq.
Martin Kane Kuper
August 4, 2021
Page 2

[Adopted 12-7-1927 as Ord. No. C-43]

386-14. Responsibility for construction and maintenance. [Amended 12-1-1992 by Ord. No. 651-92]

- A. On all streets in the City of Perth Amboy, sidewalks shall be laid and maintained in a good and safe condition by the respective owner or owners of the land thereby affected, in the manner provided by this Article.
- B. The failure of any property owner to maintain abutting sidewalks in a good and safe condition and free from any and all dangerous conditions and the proper owner's failure to repair abutting sidewalks shall constitute a violation of this Article.
- C. In the event that any property owner fails to maintain any abutting sidewalk in the condition required by this Article, the property owner shall be liable to the City of Perth Amboy for any and all costs incurred, including attorney's fees, as a result of injuries to pedestrians.

Aside from the above Ordinance, and as you already may know, New Jersey law imposes responsibility on adjoining commercial landowners to maintain the public sidewalks, keeping the sidewalk free from defects or hazardous conditions, as well as removing snow and ice from the sidewalk. *Stewart v. 104 Wallace Street, Inc.*, 87 N.J. 146 (1981) (liability for defects); *Mirza v. Filmore Corp.*, 92 N.J. 390 (1983) (liability for snow and ice). This responsibility is not dependent upon any municipal ordinance imposing the obligation. Moreover, unless the municipal entity exercises control over that specific public sidewalk, it will be immune from liability if the adjoining landowner qualifies as a commercial landowner. *Christmas v. City of Newark*, 216 N.J. Super. 393 (App. Div. 1987) (imposing no liability).

Notwithstanding this Notice, and in light of all of the above, the BID should not be named a defendant in any future lawsuit and the BID reserves all rights and remedies, including relief under the Frivolous Suit Act.

Thank you for your attention.

Very truly yours,

PASHMAN STEIN WALDER HAYDEN, P.C.



Daniel R. Guadalupe
Partner

cc: Noelia Colon, BID Executive Director
Barry Rosengarten, BID Chair



Spring Pop-Art Installation Ideas

Project Description

Project consists of pop-art installation in the location of Fink Park, intersection of Madison and Smith Street. The art should represent the spring season without the use of a flower theme as flowers were used in the previous installation. The installation will be available and open to the public free of charge for a few weeks during the months of April.

Project Goal

Seasonal Pop-up art main goal is to attract visitors to our downtown area while preserving the culture and identity of the Downtown Business District.

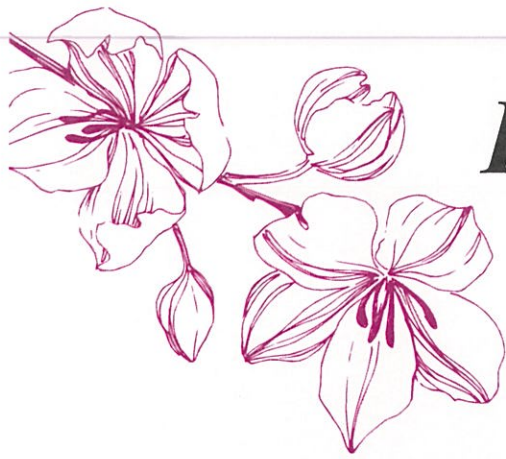

Project Ideas:

Lit Lantern Display



Unlit Lantern Display

Hanging Frame Display



Upside Down Umbrella Display



Hanging Tassel Display

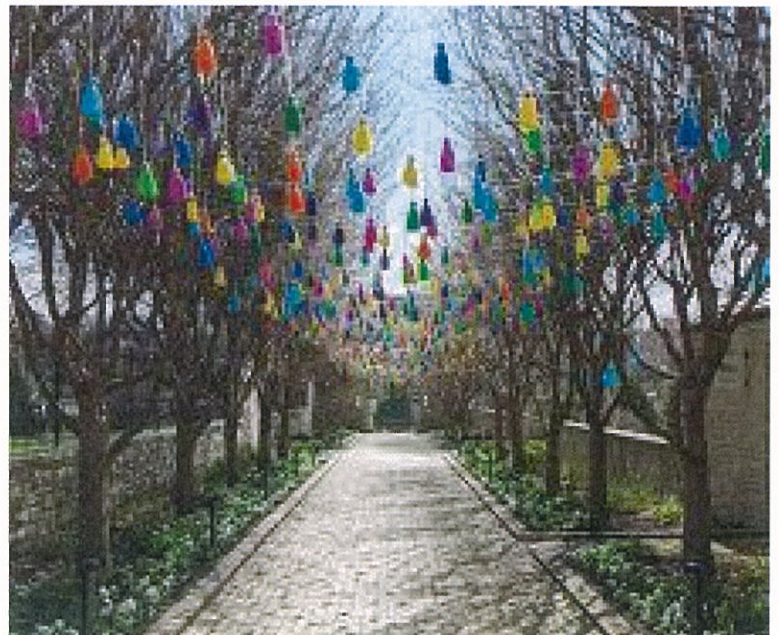

Hanging Tassel Display

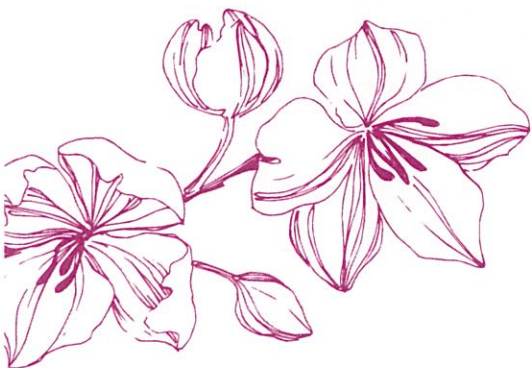

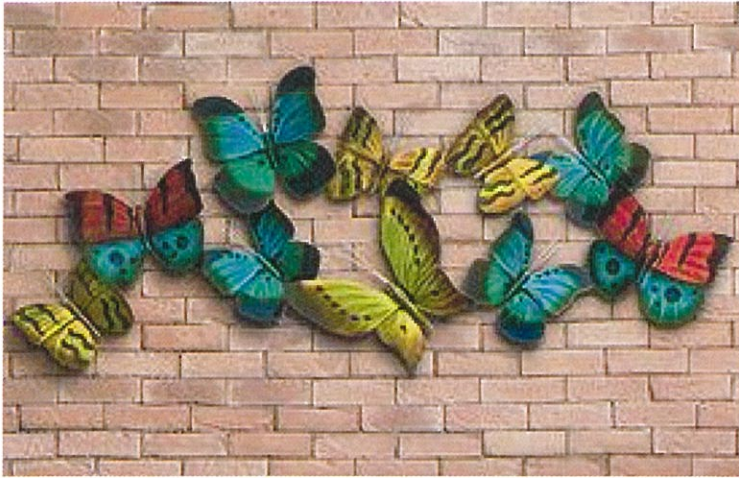

Faux Butterfly Display



Ribbon Display



Circular Ribbon Display

Large Tulip Light Display



Unlit Large Tulip Light Display

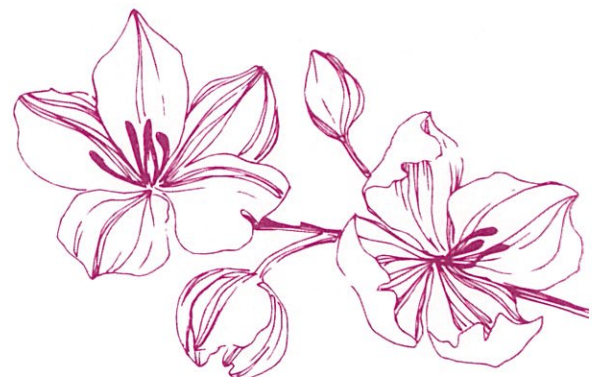

City of Perth Amboy
Business Improvement District
260 High Street, Perth Amboy, NJ, 08861
Phone (732) 442-6421 | Fax (732) 826-1160



FAÇADE APPLICATION

APPLICANT: Market Square Restaurant LLC dba Bay City Restaurant & Sports Bar
(Must be commercial property owner or commercial business)

ADDRESS: 273 High Street

CITY: Perth Amboy STATE: NJ ZIP: 08861

IMPROVEMENT REQUEST: We are seeking a grant in order to improve our facade signage.

COST OF IMPROVEMENT (Include only hard costs, no permits, architectural fees, etc. Attach proposed contractor's agreement) \$ _____. You must provide three (3) bids; grant cannot exceed \$5,000.

TOTAL PROJECT AMOUNT \$ 15,335.00.

GRANT AMOUNT \$ \$5,000.

A. AGREEMENT TO FOLLOW PERTH AMBOY BUSINESS IMPROVEMENT (PA BID) PROGRAM AND DESIGN GUIDELINES:

- a. The business must be an active UEZ certified business with the New Jersey Urban Enterprise Zone Program and must remain in the program for at least five (5) years from the date of approval of this application.
- b. The applicant hereby agrees to abide by the design guidelines developed by the PA BID for approval before construction. The City of Perth Amboy will provide a construction permit only upon submission of a Letter of Authorization from the PA BID. If the subsequent construction deviates from the PA BID authorization, the applicant will be solely responsible for the removal of the non-conforming improvement and the PA BID reserves the right to cancel the façade improvement grant.

B. AWARD FORMULA

The Perth Amboy BID will reimburse the application for hard cost expenses based on the following schedule:

50% of first \$10,000

Total \$5,000

C. SUPPLEMENTAL DOCUMENTATION NEEDED

The applicant must provide the following attachments with the application. The PA BID office can provide, if needed:

- a. Current Perth Amboy UEZ certificate or letter of waiver signed by Noelia Colon, UEZ Coordinator (form 3)
- b. Payment of current commercial property taxes via copy of paid bill or certification from Perth Amboy Tax Collection Department (form 1)
- c. Letter of authorization from property owner for improvements planned if the applicant is not the property owner (form 2)
- d. Proposed contractor's agreement
- e. If improvements are to be made by for tax-exempt tenant, the commercial property owner must be the applicant and must choose option to receive the façade improvement grant or direct PA BID to pay tenant (form 2)

D. REMINBURSEMENT DOCUMENTATION

If the application is accepted, the applicant understands that the façade improvement grant will be awarded on a reimbursement basis and that the applicant must first pay the contractor in full from its own funds. Before the grant is awarded, the applicant must provide:

- a. Copy of cancelled checks paid to the contractor(s) in the amount specified under the "Cost of Improvement"
- b. Paid receipt or contact stamped "Paid in Full" from the contractor(s) in the amount specified under "Cost of Improvement."
(Failure to provide documents will result in a delay of awarding the grant and may result in forfeiture of the grant).

E. GRANT REFUND IF BUSINESS IS CLOSED

The applicant hereby agrees that if the business closes within one (1) year after the completion of the project and the award of the grant (not the acceptance of the application,) the grant will be refunded to the PA BID.

F. APPLICATION NOTIFICATION

The PA BID Façade Committee meets monthly, generally during the second week of the month. Applications must be submitted to Noelia Colon, BID Executive Director, at the PA BID office, 260 High Street, Perth Amboy, NJ, 08861, by the last day of the prior month, to be considered at the next Façade Committee Meeting. Notification will be made to the applicant within two weeks of the committee meeting.

G. GRANT ALLOCATIONS

Due to the demand for façade improvement grants and the limited amount of funds, only one grant per property can be awarded per year, unless separate and distinct tenants within the same building apply for separate and distinct grant.

I, Bay City Restaurant & Sports Bar, applicant for a Façade Grant, hereby attest that I have read this application in full and understand and agree to all its terms.

APPLICANT



Signature

Xiomara Menza
Name (please print)

DATE: 11/11/21 x.m

VERIFICATION OF PAYMENT OF COMMERCIAL PROPERTY TAX

TO: City of Perth Amboy
FROM: Perth Amboy BID – Façade Improvement Program

The commercial property owner/business owner listed below has applied for a façade improvement grant from the Perth Amboy BID. Among our requirements is verification that payment of the commercial property tax on the property or building be current. Kindly verify below the most recent tax period paid on the subject property.

PROPERTY LOCATED AT: 270 King Street
(Street Address)

Lot Number 7.01 Block Number 56 Classification _____

Property Owner: King Plaza LLC

Business Owner: Market Square Restaurant LLC

MOST RECENT TAX PAYMENT HISTORY

Are there any tax liens and/or tax sale certificates on the property?

Yes _____ No X _____

Most Recent Payment Amount: \$ \$10,281.84

Most Recent Tax Period Covered: Year 2021 (SID TAX ONLY)
(Applicant may also submit a tax payment history print out from the Tax Collector’s Office)

PERTH AMBOY TAX COLLECTOR’S DEPARTMENT
AUTHORIZED SIGNATURE:

Name (please print)

Thank you for your cooperation. Should you have any questions, please contact the Perth Amboy BID office at: (732) 442-6421. Please give this form to applicant once completed to complete the application packet.

PROPERTY OWNER’S AUTHORIZATION OF TENANT’S FAÇADE

IMPROVEMENT APPLICATION AND/OR REQUEST TO APPLY

TO: Owner Property at 270 King Street, Perth Amboy, NJ 08861
FROM: Perth Amboy Business Improvement District Façade Improvement

Dear Property Owner:

Your tenant Market Square Restaurant LLC has submitted an application for a Façade Improvement at the property listed above. Your authorization as property owner is required to process this application. The tenant proposes the following improvement.

Installation of new facade signage

Please indicate whether you support your tenant's application. Yes No



Property Owner Signature

Xiomara Menza

Name (please print)

FOR PROPERTY OWNERS WITH "TAX EXEMPT" TENANTS

Since the tenant does not operate a commercial business and is exempt from paying commercial property taxes, it is technically ineligible for a faced improvement grant, which can only be awarded to property owners, and/or business owners who pay the PA BID tax surcharge onto their commercial property taxes. Therefore, you as the payer of the commercial property tax and PA BID tax surcharge must apply for the façade improvement grant for your building.

A Façade Improvement Grant application is attached. Kindly complete the form and apply directly on behalf of your tenant.

If you want to PA BID Reimbursement payment to be paid directly to your tenant, you must authorize here: Yes _____ No _____

Your Name: _____ Your Signature: _____
(Please print)

Phone: _____ Fax: _____

Date: _____

Note: All façade grant carry the stipulation if the improved building is marketed for sale and/or sold within one year after the project completion and award of the grant (not the acceptance of the application) the grant will be refunded in full to the PA BID. Thank you for you cooperation. Any questions, please call the BID office at (732) 442-6421. Once this form is completed, please give it to the tenant to return the same to the BID for further processing

OFFICE OF THE COLLECTOR - TREASURER

City of Perth Amboy

260 High Street, Perth Amboy, NJ 08861

Interest at 8% Per Annum 1st \$1,500 - 18% Any Amount in Excess of \$1,500
ON DELIQUENT TAXES

AUG 3 2021

KP COMMERCIAL

KINGS PLAZA PILOT
SID TAX 2021
0.119

DATE: August 1, 2021
BLOCK: 57 and 56
LOT: 12.01 and 7.01
ADDRESS:

CONTACT TAX OFFICE FOR INTEREST AMOUNTS. (732) 826-0290

	YEAR	AMOUNT	INTEREST	COSTS	TOTALS
SPECIAL IMPROVEMENT					
DISTRICT TAX					
BLOCK 57 LOT 12.01 <i>271</i>					\$ 13,521.85 ✓
BLOCK 56 LOT 7.01 <i>270</i>					10,281.84 ✓
DUE ON OR BEFORE 8/1					
Total					\$ 23,803.69

RETURN THIS NOTICE WITH YOUR PAYMENT

EM
ED
8/2/21

X 

KP Commercial LLC
 270 King St
 Perth Amboy, NJ 08861
 732-324-0300

Popular Bank
 631 State St.
 Perth Amboy, NJ 08861

No. 1291

Date 8/5/2021

Pay To The Order Of City of Perth Amboy

\$ **23,803.69

Twenty-Three Thousand Eight Hundred Three and 69/100

Dollars

City of Perth Amboy
 260 High St.
 Perth Amboy, NJ 08861



Memo:

⑈00000129⑈

KP Commercial LLC

City of Perth Amboy

Date	Type	Reference
9/5/2021	Bill	YEAR 2021:SID 270KP
5/2021	Bill	YEAR 2021:SID 271KP

Original Amt.
10,281.84
13,521.85

Balance Due
10,281.84
13,521.85

8/5/2021

Discount

Check Amount

Payment
10,281.84
13,521.85
23,803.69

1291

Pop

City of Perth Amboy

08/09/21 15:02 KING PLAZA BID ASSES

KP C

Dat
8/5/
8/5.

Block/Lot/Qual: 57 12 01
 Owner: KING PLAZA, LLC C/O ETC MGHT.
 Property Location: 271 KING ST.
 KP COMMERCIAL LLC
 KING PLAZA BID ASSES
 KING PLAZA BID ASSES
 Chk#: 1291
 Batch Id: SHDNTAL
 Ref Num: 26408 Seq: 400 to 400

Original Am
10,281.8
13,521.8

Cash Amount:	0.00
Check Amount:	13,521.85
Credit Amount:	0.00

City of Perth Amboy

08/09/21 15:03 KING PLAZA BID ASSES

23,803.69

1291

Block/Lot/Qual: 56 7 01
 Owner: KING PLAZA, LLC C/O ETC MGHT.
 Property Location: 270 KING ST.
 KP COMMERCIAL LLC
 KING PLAZA BID ASSES
 KING PLAZA BID ASSES
 Chk#: 1291
 Batch Id: SHDNTAL
 Ref Num: 26408 Seq: 401 to 401

Payment
10,281.84
13,521.85
23,803.69

Cash Amount:	0.00
Check Amount:	10,281.84
Credit Amount:	0.00

Total: 10,281.84

PopularBank#206

23,803.69



DESIGN - FABRICATION - INSTALLATION

891 State St., Perth Amboy NJ 08861
P. (732) 442-8080 • F. (732) 442-3113

QUOTE

Location Information: 273 High Street Perth Amboy, NJ 08861	Client Name Bay City Restaurant Address: 273 High Street Perth Amboy, NJ 08861 Contact: Eddie 732-259-3880	Quote Date: 10/20/2021 Project #: Quote #: 10732 Questions? 732.442.8080 infosales.nc@gmail.com
Requested Amount to Start Production: \$7,667.50		

DESCRIPTION:

- 1- New Entrance Canopy 9'-0" w X 3'-0" h X 12'-0" l w/ 2 Posts, Backlit Logo, and a LED Light Fixture \$3,685.00
- 1- Bay City Logo 10'-0" w X 4'-4" h X 4" d \$3,500.00
Illuminated Channel Letters: 23" h (White and Yellow)
Backing: .125 Aluminum Primed and Painted (Black) w/ Matthews Products
- 1- Set of 1" Thick PVC Letters \$1,000.00
Reading: "Restaurant & Sports Bar" (16" h)
- 8- New Covers for Existing Shed Style Awnings 13'-0" X 3'-0" X 2'-0" \$6,000.00
Fabric: Sunbrella Black
Includes: Take Down and Reinstall, 8- 2 Color Logos (Painted), Touch Up Frames (Blk)
- 1- Take Down and Dispose Existing Sign \$500.00
- 1- Bay City PVC Logo (for Takeout Area) \$360.00 **NO CHARGE**
- 12- "V" Carved Acrylic Logos (for Bar Counter) \$960.00 **NO CHARGE**
- 3- Clear Plastic Covers (for Front Area) \$650.00

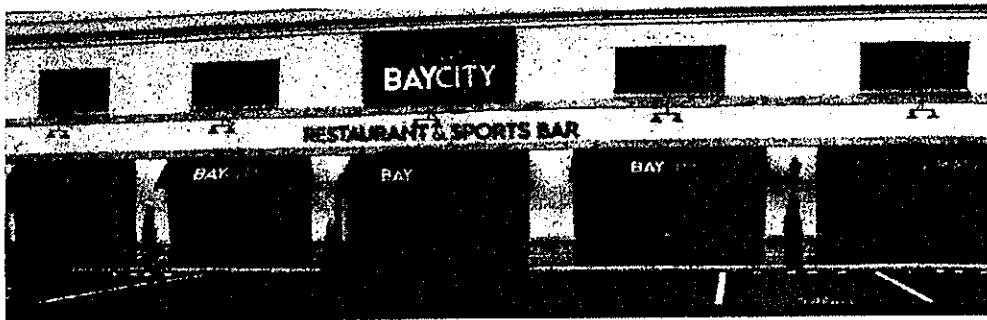

TOTAL PROJECT COST: \$15,335.00

***Please provide tax exempt. If not, NJ sales tax will be added to final invoice.**

PRICE INCLUDES: Rendering, Shop Drawing, and 5 Years Warrantee

PRICE DO NOT INCLUDES: Eggcrate Ceiling for Canopy, NJ Sales Tax, Engineered Drawing or Permit Fees

Requested Amount to Start Production: \$7,667.50
Remaining Balance After Requested Amount: \$7,667.50

1st Payment: _____

2nd Payment: _____

THANK YOU FOR DOING BUSINESS WITH US!



PROPOSAL

187 New Brunswick Ave, Perth Amboy, NJ 08861
 Phone: (732) 376-0193 Fax: 732-744-9228

NUMBER	1108-102021
DATE	10/20/2021

ALL TYPE OF PRINT - BANNERS - SIGNS - MAGNETICS AND MORE

Proposal Submitted To:

Job Site Information:

NAME: <u>BAY CITY RESTAURANT & SPORTS BAR</u>	JOB NAME: <u>BAY CITY RESTAURANT & SPORTS B.</u>
ADDRESS: <u>273 HIGH STREET</u>	JOB LOCATION: <u>273 HIGH STREET</u>
CITY: <u>PERTH AMBOY</u> STATE: <u>NJ</u> ZIP CODE: <u>08861</u>	PHONE: <u>732-324-0300</u>

INCLUDED IN PRICE:

- 1- 10'-0"Wx4'-0"Hx4"D. SIGN W/ 7- 23" illuminated Channel Letters
 Reading: "BAY CITY" W/ Skyline
 Colors: Black, White and Yellow.
- and 20- 16"H. 1' Thick PVC Letters. Reading: "RESTAURANT & SPORTS BAR"
- 9- New covers for Existing Awnings.
- 1- New Entrance Canopy 12'-0"Px9'-0"W
 Color: Black Sumbrella Fabric w/ White and Yellow Painted Graphics (Logos and Letters),
 Take down existing signs and Installation Using Bucket Truck.

PRICE DO NOT INCLUDES: Permits And Final Electrical Connection

TOTAL PRICE: \$ 16,448.00

"TAX EXEMPT PROJECT"

We hereby propose to furnish material and labor - Completed in accordance with the above specifications for _____ Dollars \$ **16,448.00**

Payment to be made as follows:

50% DP. and 50% COD.

Authorized Signature

x _____



PrintMediaOnline

254 Highway 34, Suite 4
Matawan, NJ 07747
Tel: 732-705-3313 • order@printmediaonline.com

Estimate

Date	Estimate #
10/18/2021	108643
Exp. Date	N/A

Address
Bay City Restaurant & Sports Bar 273 High Street Perth Amboy NJ. 08861 732-324-0300

Quantity	Description	Amount
1	<p><u>EXTERIOR SIGNAGE AND AWNING COVERS AND NEW CANOPY</u></p> <p>1- Illuminated Channel Letter Sign. Size: 10'-0"Wx4'-0"Hx4"D. Colors: Black Aluminum panel with White and Yellow Channel Letters Reading: "BAY CITY" (23") and Back-lit Skyline</p> <p>1-Cut-out Individually mounted 1' Thick PVC Sign. (16"H) Reading: "Restaurant & Sports Bar"</p> <p>1- 12'x9'x3' Canopy w/ 2 posts</p> <p>9- Covers for Existing Awnings. Color: Black Fabric with Logos and Letters. Take down existing signs and Installation are included in Price.</p> <p>PERMITS AND ELECTRICAL CONNECTION BY OTHER</p>	\$16,997.00
		SubTotal \$16,997.00
		Tax (6.625%) EXEMPT
		Total \$16,997.00

Accepted By PPJ

Accepted Date

BAY CITY RESTAURANT SPORTS BAR



RESTAURANT SPORTS BAR

BAYCITY
RESTAURANT SPORTS BAR

AFTER

BAYCITY
RESTAURANT & SPORTS BAR

RESTAURANT & SPORTS BAR

BAYCITY

RESTAURANT & SPORTS BAR

BAYCITY
RESTAURANT & SPORTS BAR

BAYCITY

RESTAURANT & SPORTS BAR

BEFORE

Ciro's

ITALIAN CUISINE

SPORTS BAR

CIRO'S
ITALIAN CUISINE

CIRO'S
RESTAURANT

Market Square Restaurant LLC
t/a BayCity Restaurant and Sports Bar
273 High Street
Perth Amboy, NJ 08861

November 12, 2021

City of Perth Amboy
Business Improvement District
260 High Street
Perth Amboy, NJ 08861
Attn: Noelia Colon

Re: Façade Grant Application

Dear Ms. Colon,

Attached please find our application for Façade Improvement. We were delayed in submitting the application due to labor shortages and scheduling conflicts with our contractor. The contractor we elected to use has significant issues with labor and his schedule was backed up into Spring 2022. The contractor informed us that he had an anticipated job fall through and so an opening arose for our project and we had to take advantage of this opening to get our signage installed. If we would have waited for his availability in the Spring, we would not have our signage correct and this would have caused severe inconsistencies and issues with our marketing and other business processes. Due to these circumstances, we felt it was necessary to install the signage prior to submitting and/or having approved our Façade Grant application.

Sincerely,



Xiomara Menza
Market Square Restaurant LLC

VERIFICATION OF PAYMENT OF COMMERCIAL PROPERTY TAX

TO: City of Perth Amboy
FROM: Perth Amboy BID – Façade Improvement Program

The commercial property owner/business owner listed below has applied for a façade improvement grant from the Perth Amboy BID. Among our requirements is verification that payment of the commercial property tax on the property or building be current. Kindly verify below the most recent tax period paid on the subject property.

PROPERTY LOCATED AT: 270 King Street
(Street Address)

Lot Number 7.01 Block Number 56 Classification _____

Property Owner: King Plaza LLC

Business Owner: Market Square Restaurant LLC

MOST RECENT TAX PAYMENT HISTORY

Are there any tax liens and/or tax sale certificates on the property?

Yes _____ No X

Most Recent Payment Amount: \$ \$10,281.84

Most Recent Tax Period Covered: Year 2021 (SID TAX ONLY)
(Applicant may also submit a tax payment history print out from the Tax Collector’s Office)

PERTH AMBOY TAX COLLECTOR’S DEPARTMENT
AUTHORIZED SIGNATURE:

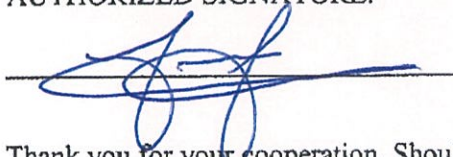

Juan Martinez
Name (please print)

Thank you for your cooperation. Should you have any questions, please contact the Perth Amboy BID office at: (732) 442-6421. Please give this form to applicant once completed to complete the application packet.

PROPERTY OWNER’S AUTHORIZATION OF TENANT’S FAÇADE

BLQ: 56. 7.01 Tax Year: 2020 to 2021
Owner Name: KING PLAZA, LLC C/O ETC MGNT. Property Location: 270 KING ST.

Tax Year: 2020	Qtr 1	Qtr 2	Qtr 3	Qtr 4	Total
Payments:	0.00	0.00	0.00	0.00	0.00
Balance:	0.00	0.00	0.00	0.00	0.00

Date	Qtr	Type	Code	Check No	Mthd	Reference	Batch Id	Principal	Interest	2020 Prin Balance
		Description								
		Original Billed						0.00		0.00

Tax Year: 2021	Qtr 1	Qtr 2	Qtr 3	Qtr 4	Total
Payments:	0.00	0.00	0.00	0.00	0.00
Balance:	0.00	0.00	0.00	0.00	0.00

Date	Qtr	Type	Code	Check No	Mthd	Reference	Batch Id	Principal	Interest	2021 Prin Balance
		Description								
		Original Billed						0.00		0.00

Total Principal Balance for Tax Years in Range: 0.00

Miscellaneous Payments for Date Range 01/01/20 to 12/31/21:

Date	Type	Code	Check No	Mthd	Reference	Batch Id	Principal	Interest	Total
01/20/21	Payment	E27	H0366993	CK	24130 188	SMONTAL	56,250.00	0.00	56,250.00
		KINGS PLAZA			IN LIEU KING PLAZA				<u>56,250.00</u>

City of Perth Amboy
Business Improvement District
260 High Street, Perth Amboy, NJ, 08861
Phone (732) 442-6421 | Fax (732) 826-1160

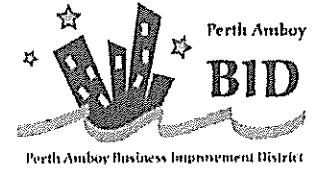

FAÇADE APPLICATION

APPLICANT: Santibana Travel (HFI Insurance Agency)
(Must be commercial property owner or commercial business)

ADDRESS: 362 State Street

CITY: Perth Amboy STATE: NJ ZIP: 08861

IMPROVEMENT REQUEST: Office Sign Update, New Awning
and window decals, Painting Storefront, Replacem
Aluminum screen

COST OF IMPROVEMENT (Include only hard costs, no permits, architectural fees, etc.
Attach proposed contractor's agreement) \$ 9,780.. You must provide three (3) bids; grant
cannot exceed \$5,000.

TOTAL PROJECT AMOUNT \$ 9,780.00

GRANT AMOUNT \$ 4890.00.

A. AGREEMENT TO FOLLOW PERTH AMBOY BUSINESS IMPROVEMENT (PA BID) PROGRAM AND DESIGN GUIDELINES:

- a. The business must be an active UEZ certified business with the New Jersey Urban Enterprise Zone Program and must remain in the program for at least five (5) years from the date of approval of this application.
- b. The applicant hereby agrees to abide by the 2003-2004 design guidelines developed by the PA BID for approval before construction. The City of Perth Amboy will provide a construction permit only upon submission of a Letter of Authorization from the PA BID. If the subsequent construction deviates from the PA BID authorization, the applicant will be solely responsible for the removal of the non-conforming improvement and the PA BID reserves the right to cancel the façade improvement grant.

B. AWARD FORMULA

The Perth Amboy BID will reimburse the application for hard cost expenses based on the following schedule:

50% of first \$10,000

Total \$5,000

C. SUPPLEMENTAL DOCUMENTATION NEEDED

The applicant must provide the following attachments with the application. The PA BID office can provide, if needed:

- a. Current Perth Amboy UEZ certificate or letter of waiver signed by Noelia Colon, UEZ Coordinator (form 3)
- b. Payment of current commercial property taxes via copy of paid bill or certification from Perth Amboy Tax Collection Department (form 1)
- c. Letter of authorization from property owner for improvements planned if the applicant is not the property owner (form 2)
- d. Proposed contractor's agreement
- e. If improvements are to be made by for tax-exempt tenant, the commercial property owner must be the applicant and must choose option to receive the façade improvement grant or direct PA BID to pay tenant (form 2)

D. REMINBURSEMENT DOCUMENTATION

If the application is accepted, the applicant understands that the façade improvement grant will be awarded on a reimbursement basis and that the applicant must first pay the contractor in full from its own funds. Before the grant is awarded, the applicant must provide:

- a. Copy of cancelled checks paid to the contractor(s) in the amount specified under the "Cost of Improvement"
- b. Paid receipt or contact stamped "Paid in Full" from the contractor(s) in the amount specified under "Cost of Improvement."
(Failure to provide documents will result in a delay of awarding the grant and may result in forfeiture of the grant).

E. GRANT REFUND IF BUSINESS IS CLOSED

The applicant hereby agrees that if the business closes within one (1) year after the completion of the project and the award of the grant (not the acceptance of the application,) the grant will be refunded to the PA BID.

F. APPLICATION NOTIFICATION

The PA BID Façade Committee meets monthly, generally during the second week of the month. Applications must be submitted to Noelia Colon, BID Executive Director, at the PA BID office, 260 High Street, Perth Amboy, NJ, 08861, by the last day of the prior month, to be considered at the next Façade Committee Meeting. Notification will be made to the applicant within two weeks of the committee meeting.

G. GRANT ALLOCATIONS

Due to the demand for façade improvement grants and the limited amount of funds, only one grant per property can be awarded per year, unless separate and distinct tenants within the same building apply for separate and distinct grant.

I, Wilma R. Matey, applicant for a Façade Grant, hereby attest that I have read this application in full and understand and agree to all its terms.

APPLICANT

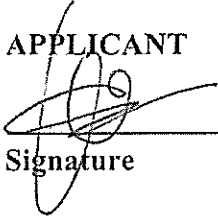

Signature

Wilma R. Matey
Name (please print)

DATE: 11/19/2021

VERIFICATION OF PAYMENT OF COMMERCIAL PROPERTY TAX

TO: City of Perth Amboy
FROM: Perth Amboy BID – Façade Improvement Program

The commercial property owner/business owner listed below has applied for a façade improvement grant from the Perth Amboy BID. Among our requirements is verification that payment of the commercial property tax on the property or building be current. Kindly verify below the most recent tax period paid on the subject property.

PROPERTY LOCATED AT: 362 State St
(Street Address)

Lot Number 14 Block Number 146 Classification _____

Property Owner: Wilne R. Matey Trustee

Business Owner: Wilne R. Matey

MOST RECENT TAX PAYMENT HISTORY

Are there any tax liens and/or tax sale certificates on the property?

Yes _____ No X

Most Recent Payment Amount: \$ 2953.87

Most Recent Tax Period Covered: 2021

(Applicant may also submit a tax payment history print out from the Tax Collector’s Office)

PERTH AMBOY TAX COLLECTOR’S DEPARTMENT
AUTHORIZED SIGNATURE:

Name (please print)

Thank you for your cooperation. Should you have any questions, please contact the Perth Amboy BID office at: (732) 442-6421. Please give this form to applicant once completed to complete the application packet.

PROPERTY OWNER’S AUTHORIZATION OF TENANT’S FAÇADE



LINCOLN

Products

595 State Street, Perth Amboy NJ 08861

T (732) 342-8080 | F (732) 342-1113

www.lincoln-lp.com/infosales-la@pmaj.com

AWNINGS, CANOPIES, SUN SHADES AND SIGNS

QUOTE

Location Information: 362 State St Perth Amboy, NJ 08861	Client Name: HFI Insurance Agency Address: 362 State St Perth Amboy, NJ 08861 Contact: Hugo 732-826-1124	Quote Date: 10/12/2021 Project #: Quote #: 107258 Questions? 732.442.8080 Infosales.la@gmail.com
Required Deposit to Start Production: \$4,890.00		

DESCRIPTION:

- 1- New Cover for Existing Awning (25'-0" X 3'-0" X 2'-0") \$5,300.00
 Fabric Color: Green Sunbrella
 Reading: HFI Insurance Agency (White)
 Price Includes: Set of Eggcrate Ceiling, 8' LED's Light Fixtures, Set of Window and Door Graphics
- 1- Cornice Restoration (Scrape, Prime, and Paint) \$3,000.00
- 1- LED's Retrofit for Double Sided Hanging Sign (6' X 4') \$1,480.00

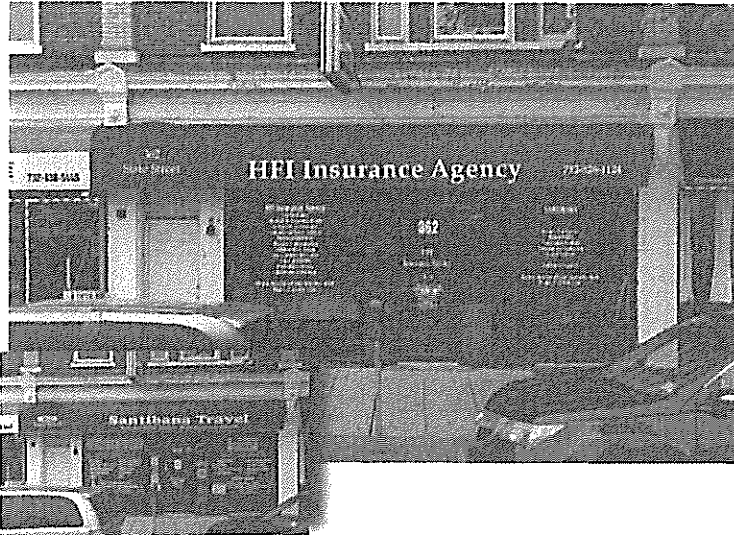

TOTAL PROJECT COST: \$9,780.00

*Price includes all materials, labor, and equipment to complete, pick up, and reinstall this project.
 Price does not include tax, permi,t or permit city fees.*

Payment Options

50% Deposit Required to Start Production: \$4,890.00
 Balance COD: \$4,890.00

1st Payment: _____ 2nd Payment: _____

THANK YOU FOR DOING BUSINESS WITH US!

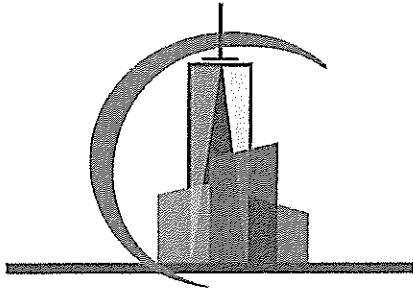

CITY PRINTING

187 New Brunswick Ave, Perth Amboy, NJ 08861
Phone: (732) 376-0193 Fax: 732-744-9228

PROPOSAL

NUMBER

1113-102221

DATE

10/22/2021

ALL TYPE OF PRINT - BANNERS - SIGNS - MAGNETICS AND MORE

Proposal Submitted To:

Job Site Information:

NAME: <u>HFI INSURANCE CO.</u>	JOB NAME: <u>HFI INSURANCE CO.</u>
ADDRESS: <u>362 STATE ST.</u>	JOB LOCATION: <u>362 STATE ST.</u>
CITY: <u>PERTH AMBOY</u> STATE: <u>NJ</u> ZIP CODE: <u>08861</u>	PHONE: <u>732-826-1124</u>

INCLUDED IN PRICE:

- 1- 25'-0"Wx3'-0"Hx2"D. Awning Cover
Color: Forest Green Fabric w/ White back- lit Graphics
Reading: "HFI INSURANCE AGENCY"
- 1- Cornice to be Restored (Painted White)
- 1 LED retrofit for existing double sided Light box sign
- 2 Window Lettering.

PRICE DO NOT INCLUDES: Permits And Final Electrical Connection

TOTAL PRICE: \$ 9,923.50

"TAX EXEMPT PROJECT"

We hereby propose to furnish material and labor - Completed in accordance with the above specifications for

_____ Dollars \$ **9,923.50**

Payment to be made as follows:

50% DP. and 50% COD.

Authorized Signature

x _____



PrintMediaOnline

254 Highway 34, Suite 4
Matawan, NJ 07747
Tel: 732-705-3313 • order@printmediaonline.com

Estimate

Date	Estimate #
11/08/2021	108660
Exp. Date	N/A

Address
HFI INSURANCE AGENCY 362 State St. Perth Amboy NJ. 08861 732-826-1124

Quantity	Description	Amount
1	<p><u>RECOVER EXISTING WATERFALL AWNING</u></p> <p>SIZE: 25'-0"Wx3'-0"Hx2"D. Color: Dark Green Fabric w/ White Lettering Reading: "HFI INSURANCE AGENCY" 1- Cornice Restoration 1 LED's Retrofit for existing double sided Light box. 2 Window Graphic color: White vinyl.</p> <p>PERMITS AND ELECTRICAL CONNECTION BY OTHER</p>	\$10,396.00
SubTotal		\$10,396.00
Tax (6.625%)		EXEMPT
Total		\$10,396.00

Accepted By PPJ

Accepted Date

HFI Insurance Agency / 362 State Street

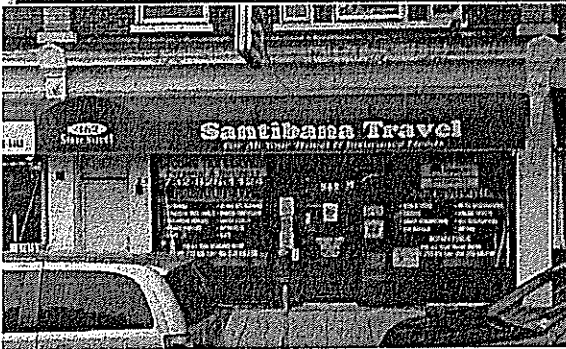

LINCOLN
Architectural Products

AWNINGS, CANOPIES, SUN SHADES AND SIGNS

891 Scate Street, Perth Amboy NJ, 09061
P: 732-442-8000 F: 732-442-3113
www.lincoln-ap.com / info@ales.lap@gmail.com

Left Window

HFI INSURANCE AGENCY

- CAR INSURANCE
- MOTORCYCLE INSURANCE
- COMMERCIAL TRUCK LIABILITY
- HOMEOWNER INSURANCE
- SPECIAL EVENT INSURANCE
- ANTIQUE AUTO INSURANCE
- BUILDERS RISK
- BUSINESS INSURANCE
- BONDS
- UMBRELLA COVERAGE
- SPECIAL FINANCING AVAILABLE

WE ARE HERE FOR ALL YOUR INSURANCE NEEDS
(732) 826-1124

Right Window

Santibana

- INCOME TAX PREPARATION
- NOTARY PUBLIC
- TRANSLATION SERVICES/SERVICIOS DE TRADUCCION
- TRAVEL SERVICES
- HABLAMOS ESPANOL

WE ARE HERE FOR ALL YOUR INSURANCE NEEDS
(732) 826-1124

Door

362
HFI INSURANCE AGENCY

Hours of Operation
Monday- Friday 10AM-6PM

VERIFICATION OF PAYMENT OF COMMERCIAL PROPERTY TAX

TO: City of Perth Amboy
FROM: Perth Amboy BID – Façade Improvement Program

The commercial property owner/business owner listed below has applied for a façade improvement grant from the Perth Amboy BID. Among our requirements is verification that payment of the commercial property tax on the property or building be current. Kindly verify below the most recent tax period paid on the subject property.

PROPERTY LOCATED AT: 362 State St
(Street Address)

Lot Number 14 Block Number 146 Classification _____

Property Owner: Wilne R. Matey Trustee

Business Owner: Wilne R Matey

MOST RECENT TAX PAYMENT HISTORY

Are there any tax liens and/or tax sale certificates on the property?

Yes _____ No X

Most Recent Payment Amount: \$ 2953.82

Most Recent Tax Period Covered: 2021
(Applicant may also submit a tax payment history print out from the Tax Collector's Office)

PERTH AMBOY TAX COLLECTOR'S DEPARTMENT
AUTHORIZED SIGNATURE:

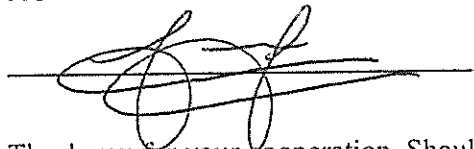

Juan Martinez
Name (please print)

Thank you for your cooperation. Should you have any questions, please contact the Perth Amboy BID office at: (732) 442-6421. Please give this form to applicant once completed to complete the application packet.

PROPERTY OWNER'S AUTHORIZATION OF TENANT'S FAÇADE

City of Perth Amboy
Business Improvement District
260 High Street, Perth Amboy, NJ, 08861
Phone (732) 442-6421 | Fax (732) 826-1160



FAÇADE APPLICATION

APPLICANT: TOWN DRUGS & SURGICAL
(Must be commercial property owner or commercial business)

ADDRESS: 164 Smith ST

CITY: Perth Amboy STATE: NJ ZIP: 08861

IMPROVEMENT REQUEST: Due to fire we moved
from 238 Smith St to 164 Smith St.

COST OF IMPROVEMENT (Include only hard costs, no permits, architectural fees, etc.
Attach proposed contractor's agreement) \$ 2640. You must provide three (3) bids; grant
cannot exceed \$5,000.

TOTAL PROJECT AMOUNT \$ 2640.

GRANT AMOUNT \$ 1320.⁰⁰.

**A. AGREEMENT TO FOLLOW PERTH AMBOY BUSINESS IMPROVEMENT
(PA BID) PROGRAM AND DESIGN GUIDELINES:**

- a. The business must be an active UEZ certified business with the New Jersey Urban Enterprise Zone Program and must remain in the program for at least five (5) years from the date of approval of this application.
- b. The applicant hereby agrees to abide by the design guidelines developed by the PA BID for approval before construction. The City of Perth Amboy will provide a construction permit only upon submission of a Letter of Authorization from the PA BID. If the subsequent construction deviates from the PA BID authorization, the applicant will be solely responsible for the removal of the non-conforming improvement and the PA BID reserves the right to cancel the façade improvement grant.

REC'D PERSONNEL
OCT 8 2021 PM 3:47

Incomplete
Application
(11)

B. AWARD FORMULA

The Perth Amboy BID will reimburse the application for hard cost expenses based on the following schedule:

50% of first \$10,000

Total \$5,000

C. SUPPLEMENTAL DOCUMENTATION NEEDED

The applicant must provide the following attachments with the application. The PA BID office can provide, if needed:

- a. Current Perth Amboy UEZ certificate or letter of waiver signed by Noelia Colon, UEZ Coordinator (form 3)
- b. Payment of current commercial property taxes via copy of paid bill or certification from Perth Amboy Tax Collection Department (form 1)
- c. Letter of authorization from property owner for improvements planned if the applicant is not the property owner (form 2)
- d. Proposed contractor's agreement
- e. If improvements are to be made by for tax-exempt tenant, the commercial property owner must be the applicant and must choose option to receive the façade improvement grant or direct PA BID to pay tenant (form 2)

D. REMINBURSEMENT DOCUMENTATION

If the application is accepted, the applicant understands that the façade improvement grant will be awarded on a reimbursement basis and that the applicant must first pay the contractor in full from its own funds. Before the grant is awarded, the applicant must provide:

- a. Copy of cancelled checks paid to the contractor(s) in the amount specified under the "Cost of Improvement"
- b. Paid receipt or contact stamped "Paid in Full" from the contractor(s) in the amount specified under "Cost of Improvement."
(Failure to provide documents will result in a delay of awarding the grant and may result in forfeiture of the grant).

E. GRANT REFUND IF BUSINESS IS CLOSED

The applicant hereby agrees that if the business closes within one (1) year after the completion of the project and the award of the grant (not the acceptance of the application,) the grant will be refunded to the PA BID.

F. APPLICATION NOTIFICATION

The PA BID Façade Committee meets monthly, generally during the second week of the month. Applications must be submitted to Noelia Colon, BID Executive Director, at the PA BID office, 260 High Street, Perth Amboy, NJ, 08861, by the last day of the prior month, to be considered at the next Façade Committee Meeting. Notification will be made to the applicant within two weeks of the committee meeting.

G. GRANT ALLOCATIONS

Due to the demand for façade improvement grants and the limited amount of funds, only one grant per property can be awarded per year, unless separate and distinct tenants within the same building apply for separate and distinct grant.

I, Padmesh Patel, applicant for a Façade Grant, hereby attest that I have read this application in full and understand and agree to all its terms.

APPLICANT

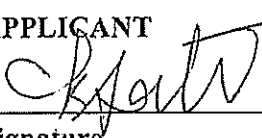
Signature

Padmesh Patel
Name (please print)

DATE: 10/1/2021

IMPROVEMENT APPLICATION AND/OR REQUEST TO APPLY

TO: Owner Property at 164 Smith St.
FROM: Perth Amboy Business Improvement District Façade Improvement

Dear Property Owner:

Your tenant EDISON DRUGS / Tower Drugs has submitted an application for a Façade Improvement at the property listed above. Your authorization as property owner is required to process this application. The tenant proposes the following improvement.

NEW Signage / Construction.

Please indicate whether you support your tenant's application. Yes No

[Signature]
Property Owner Signature

164 Smith St Perth Amboy NJ (Rigush Patel)
Name (please print)

FOR PROPERTY OWNERS WITH "TAX EXEMPT" TENANTS

Since the tenant does not operate a commercial business and is exempt from paying commercial property taxes, it is technically ineligible for a faced improvement grant, which can only be awarded to property owners, and/or business owners who pay the PA BID tax surcharge onto their commercial property taxes. Therefore, you as the payer of the commercial property tax and PA BID tax surcharge must apply for the façade improvement grant for your building.

A Façade Improvement Grant application is attached. Kindly complete the form and apply directly on behalf of your tenant.

If you want PA BID Reimbursement payment to be paid directly to your tenant, you must authorize here: Yes No

Your Name: Rigush Patel
(Please print)

Your Signature: [Signature]

Phone: 732-801-7702

Fax: _____

Date: 9/3/28

Note: All façade grant carry the stipulation if the improved building is marketed for sale and/or sold within one year after the project completion and award of the grant (not the acceptance of the application) the grant will be refunded in full to the PA BID. Thank you for you cooperation. Any questions, please call the BID office at (732) 442-6421. Once this form is completed, please give it to the tenant to return the same to the BID for further processing

AMBOY

GRAPHICS

291 NEW BRUNSWICK AVE. PERTH AMBOY NJ. 08861

732.930.5057 - 732.309.3946

TOWN DRUGS PHARMACY

CHANNEL LETTERS SIGN REPAIR.....\$2,300

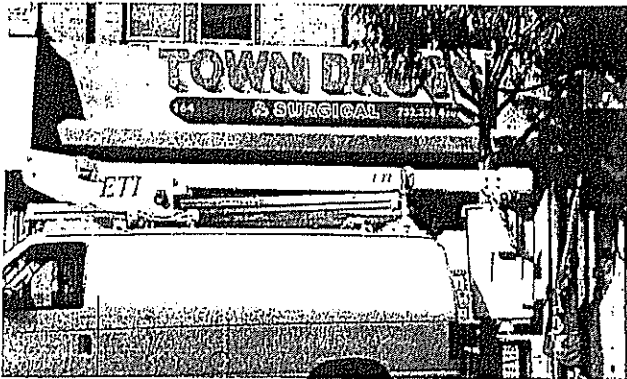

2 PROTECTION
ACRYLIC PANELS
\$340.00

INSTALLATION INCLUDED

Excludes: Electrical Feed & Permit Cost.....

TOTAL \$2,640

ck # 3268 + Advance \$1000 By Zele

\$1,340 OF DEPOSIT \$1,300 BALANCE PLUS SIGN PERMIT

Pay in full 10/01/21

09/28/2021

Julio Cesar Cabrera

**Julio Cesar Cabrera
732.309.3946**

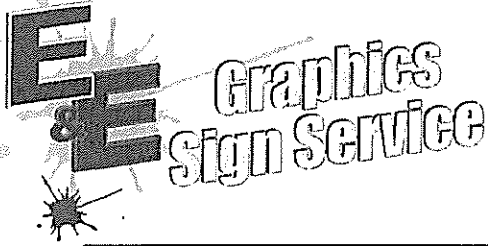

E&E Graphic Sign Service LLC
 132 Lexington Ave
 Cranford NJ 07016
 908-247-5720
 eesignservice@hotmail.com

Date	Estimate #
11-16-21	0151

Name / Address
Town Grugs Pharmacy 164 Smith St Perth Amboy NJ

Ship To
Town Grugs Pharmacy 164 Smith St Perth Amboy NJ

Account #	Rep

Quantity	Description	Price Each	Total
	Estimate for Sing Repair		
1	Channel Letters Sign Repair		2,550.00
2	Protection Acrylic Panels	195.00	390.00
	Prices Includes Labor for Installetion		
Total		\$	2,940.00

signmonkey.com

Sign Design: #318979

Print Date: 11/22/2021

Customer: towndrugs@yahoo.com

Purchase at signmonkey.com

TOWN DRUGS

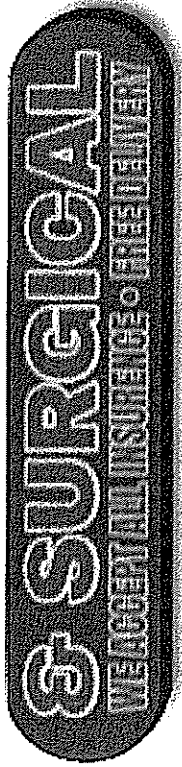

Description:

55.00" x 247.00", 94 square feet.

- Face Lit Letters, Letters: TOWN DRUGS, Style: Standard Bold, Size: 24, Face Plastic - RED, Trim for Plastic Face - RED, Side 5 inch - Black, Back, Direct (Clips), Face LEDs, EZLit plug-n-play
- Face Lit Logo Shape, Shape: *CUSTOM, Size: 55, Face Plastic - P printed, Trim for Plastic Face - Black, Side 5 inch - Black, Back, Direct (Clips), Face LEDs, EZLit plug-n-play

Sign Includes:

Your sign will come complete with everything you need to install and light your sign. The only part you will need to supply is screws from your local hardware store to attach your sign to the wall.

* Price is at time of printing, subject to change. Free shipping is for continental united states only. Shipping surcharges for some areas.

Cost: \$4812.21

Shipping: FREE

All our signs are inspected and have the  label

Installation Schematic

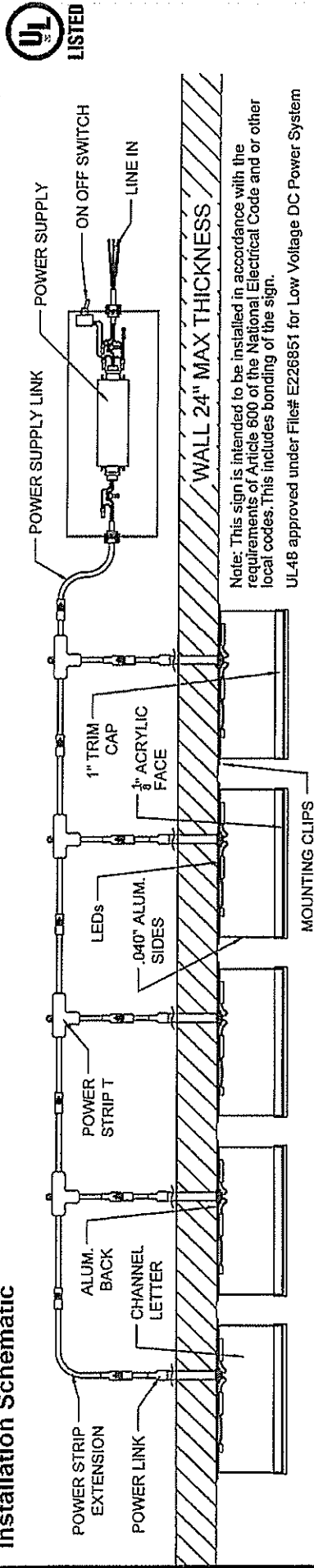

WALL 24" MAX THICKNESS

Note: This sign is intended to be installed in accordance with the requirements of Article 600 of the National Electrical Code and or other local codes. This includes bonding of the sign.

UL4B approved under File# E228851 for Low Voltage DC Power System

Installation Elevation Sign Size 55.00" H x 247.00" W, Total Sign 94 Square Feet

Estimated Electrical Load: 9 amps @ 120 volts

TOWN DRUGS

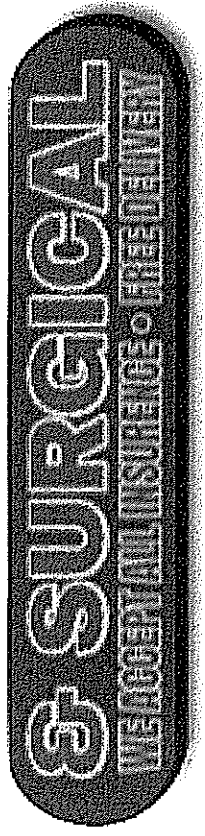

EZLit Letters & Logos Installation



Sign Parts Names referred to in the Instructions

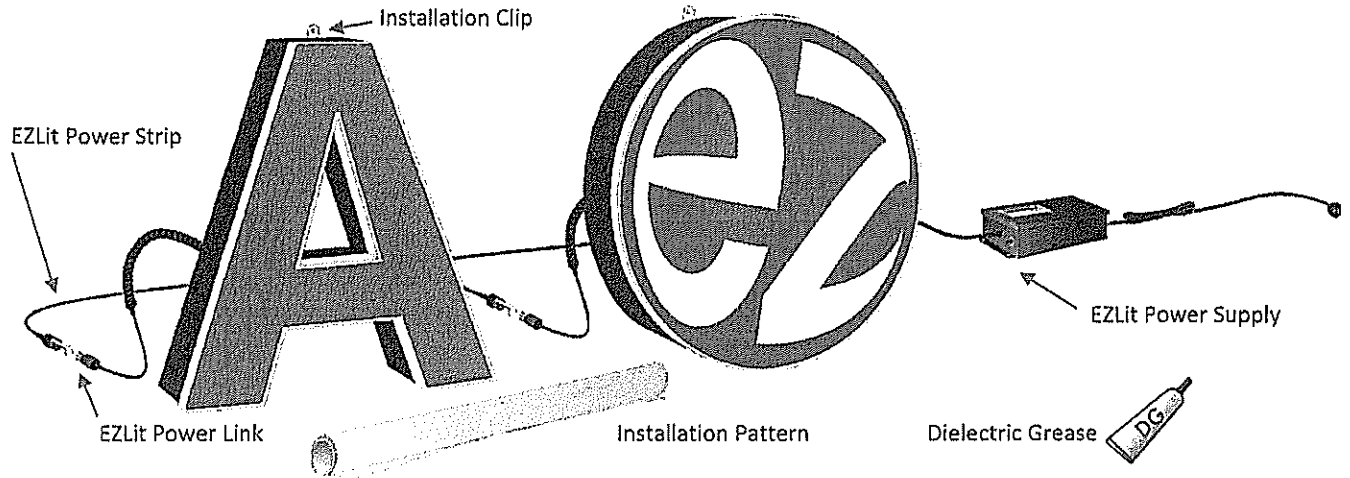

Tools Needed: Safety Glasses, Tape, Tape Measure, Level, Screws, Drill bits, Screw driver bit

Step 1

Unroll pattern and tape to wall where letters are to be installed.

Check to make sure letters are level and centered in the area.

There must be access to the back of the wall to connect EZLit Power Link to the EZLit Power Strip.

Use a tape that will not damage the wall surface when it is removed.

For brick you can use duct tape but remove as soon as done.

Do not level with the bottoms of the letters or edge of paper, use provided level lines only.

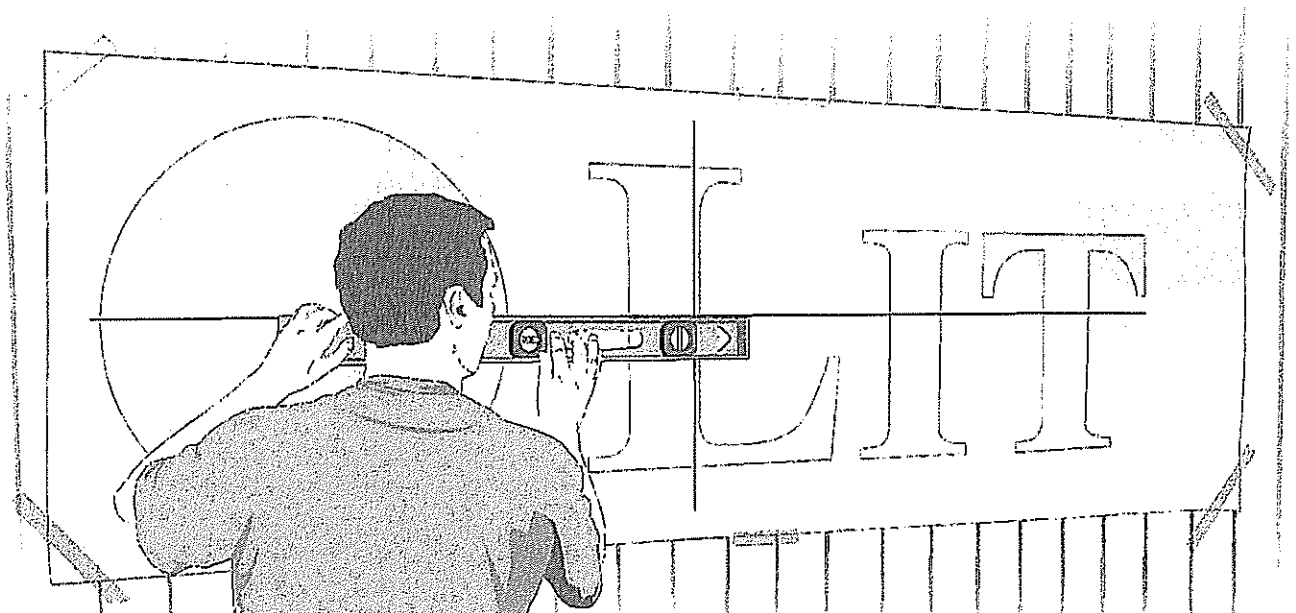

Step 2 Drill Holes

Mounting Holes  are on the outside of Letters and Logos.

Drill pilot holes through the center of the mark for appropriate fastener.

For wood surfaces we suggest galvanized wood screws. They can be painted to match wall.

Concrete, Brick or cinderblock surfaces we suggest Tapcon® Screws.

Your hardware store may suggest another type that will work for your application.

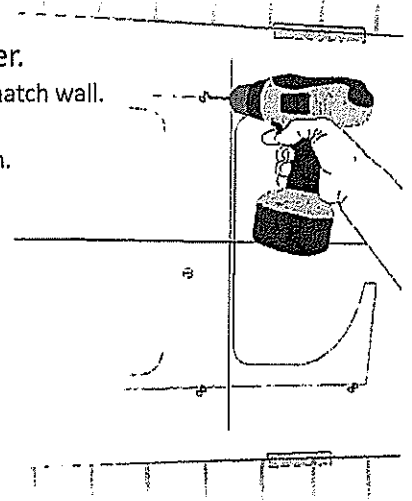
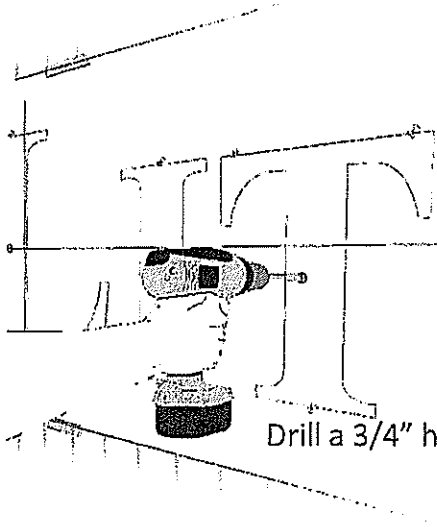

Power Holes  are in the middle of the Letters & Logos.

Drill a 3/4" hole completely through the wall to the inside of the building.

Step 3 Installing Letters

Remove the pattern from the wall.

It is best to remove tape as soon as possible.

Installation Sequence

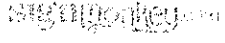
A	30-HLVR	1927851
2 of 5	OC	12VDC - 6.0 Watts
		Green PS

On the back of the Letters & Logos there is a sticker, this sticker will tell you the sequence the Letters & Logos are to be installed.

Installation Letters & Logos on the wall using screws appropriate for the wall.

Screw is to be put through hole in the mounting tab and into pilot hole from pattern.

While putting letters on the wall shove the EZLit Power Link through the wall so it can be reached from inside the building.

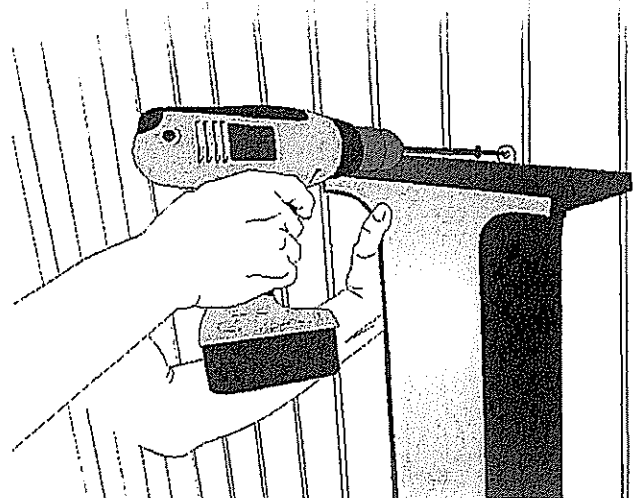
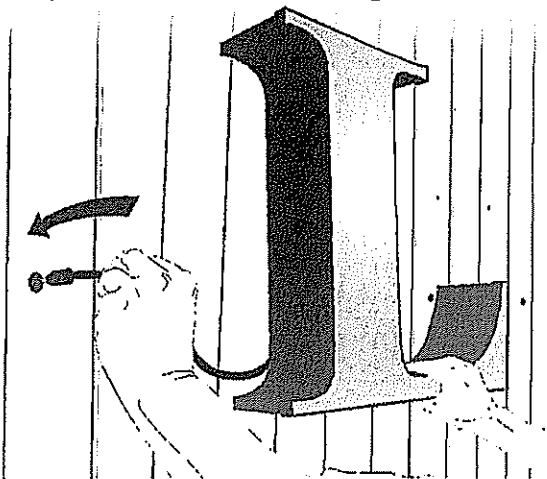

Step 4 *Install Power Strip*

On the Back side of the wall, plug each letters in to the EZLit Power Strip and the EZLit Power Supply

Each Power Link has a colored tag should match the color tag on the Power Strip.

*Apply Dielectric Grease (included with sign) to metal parts of each Plug Connection

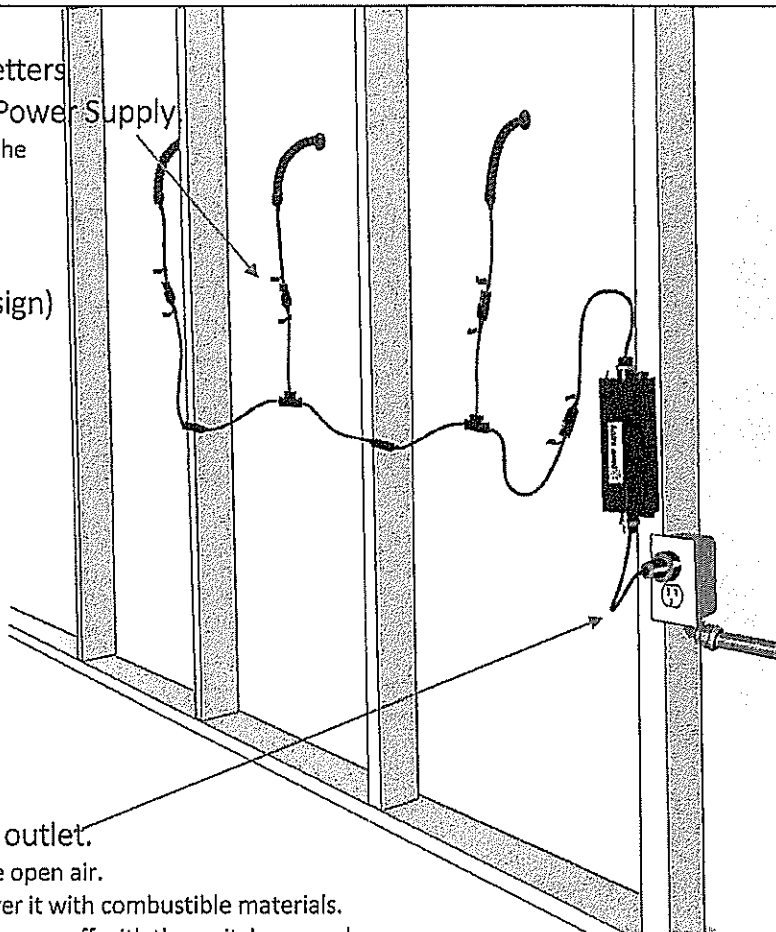

Plug the EZLit Power Strip into a 110 volt outlet.

The Power Supply gets warm and should be in the open air.

Do not put the power supply in a container or cover it with combustible materials.

The sign will be on all the time. You can turn them on or off with the switch or purchase a lamp timer at the hardware store.

Power supply must be indoors, it is not weather proof.

A loop of wire should hang down below the outlet.

This will prevent water running down cord and into the socket.



Wear Safety Glasses when drilling holes

EDISON: Account Activity Transaction Details

Check number: 00000003268

Post date: 10/01/2021

Amount: -1,300.00

Type: Check

Description: Check

Merchant name: Check

Merchant information:

Transaction category: Cash, Checks & Misc: Checks

EDISON DRUGS AND SURGICAL INC
DBA TOWN DRUGS AND SURGICAL
104 SMITH ST
PERTH AMBOY, NJ 08861-4312

3268
10-33212 NJ
3045

10/1/2021 Date

Pay To The Order Of Amboy Signs & Graphics \$ 1300.⁰⁰/₁₀₀

Thirteen hundred & no/100 Dollars

BANK OF AMERICA

ACH INT 02100039

For Front sign/Labor kgp/rtv

⑆021200039⑆00950522181⑆3268

ENDORSE HERE

Julia Costello

10/1/2021

EDISON DRUGS AND SURGICAL INC

104 SMITH ST

PERTH AMBOY, NJ 08861-4312

10/1/2021

1300.00

Amboy Signs & Graphics

Thirteen hundred & no/100

kgp/rtv

EDISON: Account Activity Transaction Details

Check number: 00000003269

Post date: 10/01/2021

Amount: -439.00

Type: Check

Description: Check

Merchant name: Check

Merchant information:

Transaction category: Cash, Checks & Misc: Checks

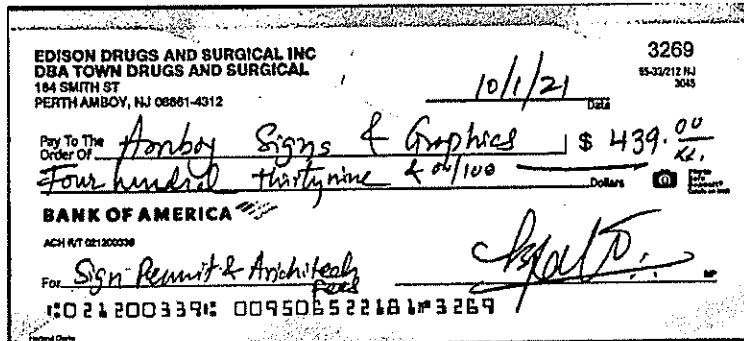

EDISON DRUGS AND SURGICAL INC
DBA TOWN DRUGS AND SURGICAL
184 SMITH ST
PERTH AMBOY, NJ 08861-4312

10/1/21

3269
05-32/12 NJ
3045

Pay To The Order Of Aronby Signs & Graphics \$ 439.00
Four hundred thirty nine & 00/100 Dollars

BANK OF AMERICA

ACH (RT) 021200330

For: Sign Permit & Architeckal Perk

⑆021200330⑆00950552218103269

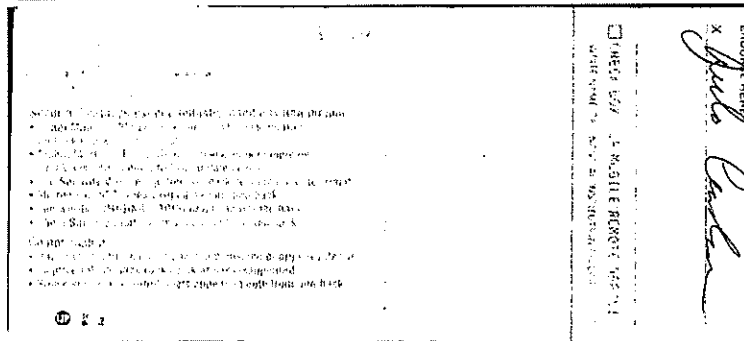

ENDORSE HERE

John C. Carter

⑆021200330⑆00950552218103269

⑆021200330⑆00950552218103269

EDISON: Account Activity Transaction Details

Post date: 07/01/2021

Amount: -1,000.00

Type: Transfer

Description: Zelle Transfer Conf# vq5ls25qk; Amboy Sign and Graphics

Merchant name: AMBOY SIGN AND GRAPHICS 

Merchant information:

Transaction category: Cash, Checks & Misc: Other Expenses

VERIFICATION OF PAYMENT OF COMMERCIAL PROPERTY TAX

TO: City of Perth Amboy
FROM: Perth Amboy BID – Façade Improvement Program

The commercial property owner/business owner listed below has applied for a façade improvement grant from the Perth Amboy BID. Among our requirements is verification that payment of the commercial property tax on the property or building be current. Kindly verify below the most recent tax period paid on the subject property.

PROPERTY LOCATED AT: 164 Smith St
(Street Address)

Lot Number 4 Block Number 125 Classification _____

Property Owner: Piyush (Paul) Patel

Business Owner: Padmesh Patel. (201) 779-7922

MOST RECENT TAX PAYMENT HISTORY

Are there any tax liens and/or tax sale certificates on the property?

Yes _____ No

Most Recent Payment Amount: \$ 7508.70

Most Recent Tax Period Covered: 2021 3+4th QTR
(Applicant may also submit a tax payment history print out from the Tax Collector's Office)

PERTH AMBOY TAX COLLECTOR'S DEPARTMENT
AUTHORIZED SIGNATURE:

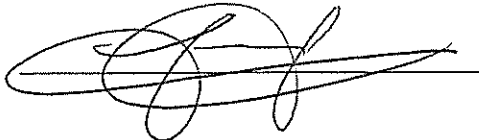

Juan Martinez
Name (please print)

Thank you for your cooperation. Should you have any questions, please contact the Perth Amboy BID office at: (732) 442-6421. Please give this form to applicant once completed to complete the application packet.

PROPERTY OWNER'S AUTHORIZATION OF TENANT'S FAÇADE

BLQ: 125. 4.
Owner Name: 164 SMITH ST. PLAZA, LLC

Tax Year: 2020 to 2021
Property Location: 164 SMITH ST.

Tax Year: 2020	Qtr 1	Qtr 2	Qtr 3	Qtr 4	Total
Original Billed:	3,775.01	3,775.00	3,826.04	3,719.11	15,095.16
Payments:	3,775.01	3,775.00	3,826.04	3,719.11	15,095.16
Balance:	0.00	0.00	0.00	0.00	0.00

Date	Qtr	Type	Code	Check No	Mthd	Reference	Batch Id	Principal	Interest	2020 Prin Balance
								15,095.16		15,095.16
01/13/20	1	Payment	001	3773106772	CK	20521	14 ONLINE1	3,775.01	0.00	11,320.15
		online payments								
01/13/20	2	Payment	001	3773106772	CK	20521	15 ONLINE1	3,775.00	0.00	7,545.15
		online payments								
08/31/20	3	Payment	001	3788168057	CK	22667	2 ONL10831	3,826.04	43.40	3,719.11
		online payments								
09/07/20	4	Payment	001	3788630113	CK	22735	7 ONL10907	3,719.11	0.00	0.00
		online payments								

Tax Year: 2021	Qtr 1	Qtr 2	Qtr 3	Qtr 4	Total
Original Billed:	3,773.79	3,773.79	3,754.35	3,754.35	15,056.28
Payments:	3,773.79	3,773.79	3,754.35	3,754.35	15,056.28
Balance:	0.00	0.00	0.00	0.00	0.00

Date	Qtr	Type	Code	Check No	Mthd	Reference	Batch Id	Principal	Interest	2021 Prin Balance
								15,056.28		15,056.28
01/01/21	1	Payment	001	3795813892	CK	23988	13 ONLINE1	3,773.79	0.00	11,282.49
		online payments								
01/25/21	2	Payment	001	3797357867	CK	24198	7 ONL10125	3,773.79	0.00	7,508.70
		online payments								
08/04/21	3	Payment	001	3811773558	CK	26391	24 ONLINE1	3,754.35	0.00	3,754.35
		online payments								
08/04/21	4	Payment	001	3811773558	CK	26391	25 ONLINE1	3,754.35	0.00	0.00
		online payments								

Total Principal Balance for Tax Years in Range: 0.00

Edison Drugs & Surgical, Inc.
DBA Town Drugs & Surgical
164 Smith Street
Perth Amboy, NJ 08861
Phone (732) 324-4200 | Fax (732) 324-4201

November 22th, 2021

City of Perth Amboy
Business Improvement District
260 High Street, Perth Amboy, NJ, 08861
Phone (732) 442-6421 | Fax (732) 826-1160

To Whom it May Concern,

This letter is to urge you to accept the request for a grant for our new signage at 164 Smith Street. Due to a fire at our old location at 238 Smith Street, we were forced to move to a new location. The New Jersey Board of Pharmacy requires signage in order to operate our pharmacy, so we had to purchase a new sign before receiving an approval for a grant. The move was very stressful and costly, so we would very much appreciate a reimbursement on the signage expense.

When I purchased the sign, I obtained three quotes and chose the cheapest one, as per your rules for reimbursement. I purchased the sign from Amboy Signage & Graphics for \$2,640. I have sent proof of the quotes and the final purchase along with this letter.

Thank you in advance. If you have any further questions, feel free to email me at towndrugs@yahoo.com or call at (732) 324-4200.

Sincerely,

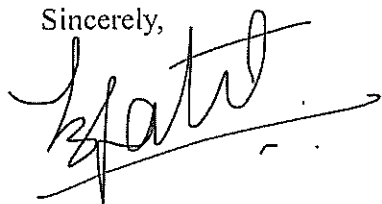
A handwritten signature in black ink, appearing to read 'P. Patel', with a long horizontal flourish extending to the right.

Padmesh Patel

City of Perth Amboy
Business Improvement District
260 High Street, Perth Amboy, NJ, 08861
Phone (732) 442-6421 | Fax (732) 826-1160



FAÇADE APPLICATION

APPLICANT: Inman Medical Associates
(Must be commercial property owner or commercial business)

ADDRESS: 322 State Street

CITY: Perth Amboy STATE: NJ ZIP: 08861

IMPROVEMENT REQUEST: AWNING SIGN REPLACEMENT

COST OF IMPROVEMENT (Include only hard costs, no permits, architectural fees, etc.
Attach proposed contractor's agreement) \$ 3145.44. You must provide three (3) bids; grant
cannot exceed \$5,000.

TOTAL PROJECT AMOUNT \$ 3145.44.

GRANT AMOUNT \$ 1572.72.

A. AGREEMENT TO FOLLOW PERTH AMBOY BUSINESS IMPROVEMENT (PA BID) PROGRAM AND DESIGN GUIDELINES:

- a. The business must be an active UEZ certified business with the New Jersey Urban Enterprise Zone Program and must remain in the program for at least five (5) years from the date of approval of this application.
- b. The applicant hereby agrees to abide by the design guidelines developed by the PA BID for approval before construction. The City of Perth Amboy will provide a construction permit only upon submission of a Letter of Authorization from the PA BID. If the subsequent construction deviates from the PA BID authorization, the applicant will be solely responsible for the removal of the non-conforming improvement and the PA BID reserves the right to cancel the façade improvement grant.

B. AWARD FORMULA

The Perth Amboy BID will reimburse the application for hard cost expenses based on the following schedule:

50% of first \$10,000

Total \$5,000

C. SUPPLEMENTAL DOCUMENTATION NEEDED

The applicant must provide the following attachments with the application. The PA BID office can provide, if needed:

- a. Current Perth Amboy UEZ certificate or letter of waiver signed by Noelia Colon, UEZ Coordinator (form 3)
- b. Payment of current commercial property taxes via copy of paid bill or certification from Perth Amboy Tax Collection Department (form 1)
- c. Letter of authorization from property owner for improvements planned if the applicant is not the property owner (form 2)
- d. Proposed contractor's agreement
- e. If improvements are to be made by for tax-exempt tenant, the commercial property owner must be the applicant and must choose option to receive the façade improvement grant or direct PA BID to pay tenant (form 2)

D. REMINBURSEMENT DOCUMENTATION

If the application is accepted, the applicant understands that the façade improvement grant will be awarded on a reimbursement basis and that the applicant must first pay the contractor in full from its own funds. Before the grant is awarded, the applicant must provide:

- a. Copy of cancelled checks paid to the contractor(s) in the amount specified under the "Cost of Improvement"
- b. Paid receipt or contact stamped "Paid in Full" from the contractor(s) in the amount specified under "Cost of Improvement."
(Failure to provide documents will result in a delay of awarding the grant and may result in forfeiture of the grant).

E. GRANT REFUND IF BUSINESS IS CLOSED

The applicant hereby agrees that if the business closes within one (1) year after the completion of the project and the award of the grant (not the acceptance of the application,) the grant will be refunded to the PA BID.

F. APPLICATION NOTIFICATION

The PA BID Façade Committee meets monthly, generally during the second week of the month. Applications must be submitted to Noelia Colon, BID Executive Director, at the PA BID office, 260 High Street, Perth Amboy, NJ, 08861, by the last day of the prior month, to be considered at the next Façade Committee Meeting. Notification will be made to the applicant within two weeks of the committee meeting.

G. GRANT ALLOCATIONS

Due to the demand for façade improvement grants and the limited amount of funds, only one grant per property can be awarded per year, unless separate and distinct tenants within the same building apply for separate and distinct grant.

I, Padmaja Isukapalli, applicant for a Façade Grant, hereby attest that I have read this application in full and understand and agree to all its terms.

APPLICANT

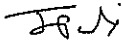

Signature

Padmaja Isukapalli
Name (please print)

DATE: 11/9/2021

VERIFICATION OF PAYMENT OF COMMERCIAL PROPERTY TAX

TO: City of Perth Amboy

FROM: Perth Amboy BID – Façade Improvement Program

The commercial property owner/business owner listed below has applied for a façade improvement grant from the Perth Amboy BID. Among our requirements is verification that payment of the commercial property tax on the property or building be current. Kindly verify below the most recent tax period paid on the subject property.

PROPERTY LOCATED AT: 322 State Street
(Street Address)

Lot Number 40 Block Number 128 Classification _____

Property Owner: PARAMOUNT ASSETS

Business Owner: Inman Medical Associates

MOST RECENT TAX PAYMENT HISTORY

Are there any tax liens and/or tax sale certificates on the property?

Yes _____ No _____

Most Recent Payment Amount: \$ _____

Most Recent Tax Period Covered: _____

(Applicant may also submit a tax payment history print out from the Tax Collector’s Office)

PERTH AMBOY TAX COLLECTOR’S DEPARTMENT

AUTHORIZED SIGNATURE:

_____ Name (please print)

Thank you for your cooperation. Should you have any questions, please contact the Perth Amboy BID office at: (732) 442-6421. Please give this form to applicant once completed to complete the application packet.

PROPERTY OWNER’S AUTHORIZATION OF TENANT’S FAÇADE

IMPROVEMENT APPLICATION AND/OR REQUEST TO APPLY

TO: Owner Property at 322 State St, Perth Amboy, NJ 08861
FROM: Perth Amboy Business Improvement District Façade Improvement

Dear Property Owner:

Your tenant Inman Medical Associates has submitted an application for a Façade Improvement at the property listed above. Your authorization as property owner is required to process this application. The tenant proposes the following improvement.

Awning sign replacement

Please indicate whether you support your tenant's application. Yes No

James Snyder
Property Owner Signature

James Snyder
Name (please print)

FOR PROPERTY OWNERS WITH "TAX EXEMPT" TENANTS

Since the tenant does not operate a commercial business and is exempt from paying commercial property taxes, it is technically ineligible for a faced improvement grant, which can only be awarded to property owners, and/or business owners who pay the PA BID tax surcharge onto their commercial property taxes. Therefore, you as the payer of the commercial property tax and PA BID tax surcharge must apply for the façade improvement grant for your building.

A Façade Improvement Grant application is attached. Kindly complete the form and apply directly on behalf of your tenant.

If you want to PA BID Reimbursement payment to be paid directly to your tenant, you must authorize here: Yes No

Your Name: _____ Your Signature: _____
(Please print)

Phone: _____ Fax: _____

Date: _____

Note: All façade grant carry the stipulation if the improved building is marketed for sale and/or sold within one year after the project completion and award of the grant (not the acceptance of the application) the grant will be refunded in full to the PA BID. Thank you for you cooperation. Any questions, please call the BID office at (732) 442-6421. Once this form is completed, please give it to the tenant to return the same to the BID for further processing

Signs2go llc

3211 Route 27 Suite#4
Franklin Park, NJ 08823
(848) 219-6533
Contact@signs2go.nj.com



Estimate

ADDRESS
PRIMARY MEDICAL CARE
322 STATE STREET
PERTH AMBOY, NJ 08861

SHIP TO
PRIMARY MEDICAL CARE
322 STATE STREET
PERTH AMBOY, NJ 08661

ESTIMATE 1792
DATE 11/08/2021

DATE	ACTIVITY	DESCRIPTION	QTY	RATE	AMOUNT
11/08/2021	Awnings	NEWAWNING 18 FT	1	2,950.00	2,950.00T

SUBTOTAL	2,950.00
TAX	195.44
TOTAL	\$3,145.44

Accepted By

Accepted Date



Ace Sign Company, Inc
 419 Summit Ave
 PO Box 66
 Perth Amboy, NJ 08862
 732.826.3858

Quote

Date	Quote #
11/5/2021	3903

Name / Address
Primary Medical Care 322 State Street Perth Amboy, NJ 08861



**** ROUGH ESTIMATE ONLY ****
 Price is subject to change.

Access behind sign area by others.
 Proper blocking by others
 Access to front of sign location to setup equipment is required.
 Any unforeseen obstruction underground or on building facade
 will be an additional cost.

Quotes valid for 15 days.

Work Order

Description	Qty	Rate	Total
Supply & Install 1 new awning with heat fused graphics. Includes new frame.		3,535.00	3,535.00T

*Permit by other, unless requested
 *Footing by other, unless requested
 (Based on normal excavation)

For Dunkin customers: Quotes do not include screens, microphones, speakers, or cameras for menu boards.

Subtotal	\$3,535.00
-----------------	------------

All connections and hook up by others.

Sales Tax (6.625%)	\$234.19
---------------------------	----------

*Signed and sealed Engineer plans additional charge if required by township
 *Electric to sign by other
 **50% deposit required prior to project commencing

3% processing fee will be added to all credit card payments.

Balance is due upon completion

Total	\$3,769.19
--------------	------------

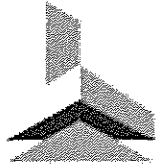

LINCOLN

Products

895 State Street, Perth Amboy NJ 08861

P. (732) 442-8080 | F. (732) 442-3113

www.lincoln-ap.com / infosales.la@gmail.com

AWNINGS, CANOPIES, SUN SHADES AND SIGNS

QUOTE

Location Information: 322 State St., Perth Amboy, NJ 08861	Client Name: Inman Medical Address: 322 State St., Perth Amboy, NJ 08861 Contact: Dr. Jain 908-222-8400	Quote Date: 10/14/2021 Project #: Quote #: 10606B Questions? 732.442.8080 Infosales.la@gmail.com
Requested Amount to Start Production: \$1,487.50		

DESCRIPTION:

1- New Waterfall Awning \$2,975.00
 Size: 15'-0" X 4'-0" X 2'-0"P
 Fabric: Blue Sunbrella
 Reading: "INMAN MEDIACL CARE" "DR. JAIN / DR. ISUKAPALLI"
 "322" "732-751-4200"



TOTAL PROJECT COST: \$2,975.00

Price includes disposing of old awning, all materials, labor, and equipment to complete, pick up, and reinstall this project.

Price does not include tax or permit city fees.

Payment Options

Requested Amount to Start Production: \$1,487.50

Balance COD: \$1,487.50

1st Payment: _____

2nd Payment: _____

THANK YOU FOR DOING BUSINESS WITH US!

VERIFICATION OF PAYMENT OF COMMERCIAL PROPERTY TAX

TO: City of Perth Amboy
FROM: Perth Amboy BID – Façade Improvement Program

The commercial property owner/business owner listed below has applied for a façade improvement grant from the Perth Amboy BID. Among our requirements is verification that payment of the commercial property tax on the property or building be current. Kindly verify below the most recent tax period paid on the subject property.

PROPERTY LOCATED AT: 322 State Street
(Street Address)

Lot Number 40 Block Number 128 Classification _____

Property Owner: PARAMOUNT ASSETS

Business Owner: Inman Medical Associates

MOST RECENT TAX PAYMENT HISTORY

Are there any tax liens and/or tax sale certificates on the property?

Yes _____ No _____

Most Recent Payment Amount: \$ _____

Most Recent Tax Period Covered: _____
(Applicant may also submit a tax payment history print out from the Tax Collector's Office)

PERTH AMBOY TAX COLLECTOR'S DEPARTMENT
AUTHORIZED SIGNATURE:

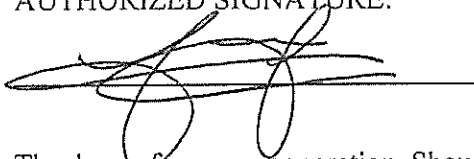

Juan Martinez
Name (please print)

Thank you for your cooperation. Should you have any questions, please contact the Perth Amboy BID office at: (732) 442-6421. Please give this form to applicant once completed to complete the application packet.

PROPERTY OWNER'S AUTHORIZATION OF TENANT'S FAÇADE

BLQ: 128. 40.
Owner Name: 322 STATE, LLC

Tax Year: 2020 to 2021
Property Location: 322-324 STATE ST/111 JEFF

Tax Year: 2020	Qtr 1	Qtr 2	Qtr 3	Qtr 4	Total
Original Billed:	5,223.65	5,223.64	5,294.26	5,146.30	20,887.85
Payments:	5,223.65	5,223.64	5,294.26	5,146.30	20,887.85
Balance:	0.00	0.00	0.00	0.00	0.00

Date	Qtr	Type	Code	Check No	Mthd	Reference	Batch Id	Principal	Interest	2020 Prin Balance
								20,887.85		20,887.85
02/07/20	1	Payment	001	CORELOGIC	CK	20740	31 CORELOGI	5,223.65	0.00	15,664.20
		Description								
										Original Billed
										1ST QUARTER TAXES
05/08/20	2	Payment	001	CORELOGIC	CK	21526	33 NAM	5,223.64	0.00	10,440.56
		Description								
										2ND QUARTER TAXES
08/10/20	3	Payment	001	CORELOGIC	CM CK	22427	29 NAM	5,294.26	0.00	5,146.30
		Description								
										3RD QUARTER TAXES
11/05/20	4	Payment	001	CORELOGIC	CO CK	23377	36 NAM	5,146.30	0.00	0.00
		Description								
										4TH QUARTER TAXES

Tax Year: 2021	Qtr 1	Qtr 2	Qtr 3	Qtr 4	Total
Original Billed:	5,221.97	5,221.96	5,195.07	5,195.06	20,834.06
Payments:	5,221.97	5,221.96	5,195.07	5,195.06	20,834.06
Balance:	0.00	0.00	0.00	0.00	0.00

Date	Qtr	Type	Code	Check No	Mthd	Reference	Batch Id	Principal	Interest	2021 Prin Balance
								20,834.06		20,834.06
02/09/21	1	Payment	001	CORELOGIC	CO CK	24383	34 NAM	5,221.97	0.00	15,612.09
		Description								
										Original Billed
										1st QUARTER TAXES
05/06/21	2	Payment	001	CORELOGIC	CK	25456	35 NAM	5,221.96	0.00	10,390.13
		Description								
										2nd QUARTER TAXES
09/03/21	3	Payment	001	CORELOGIC	CK	26762	38 NAM	5,195.07	0.00	5,195.06
		Description								
										3rd quarter taxes
11/09/21	4	Payment	001	CORELOGIC	CK	27667	37 CORELOGI	5,195.06	0.00	0.00
		Description								
										4th quarter wire

Total Principal Balance for Tax Years in Range: 0.00

City of Perth Amboy
Business Improvement District
260 High Street, Perth Amboy, NJ, 08861
Phone (732) 442-6421 | Fax (732) 826-1160



FAÇADE APPLICATION

APPLICANT: Aliah Multi Services Center LLC
(Must be commercial property owner or commercial business)

ADDRESS: 313 State Street, Suite 103

CITY: Perth Amboy STATE: NJ ZIP: 08861

IMPROVEMENT REQUEST: Logo and channel letter
sign exterior, window and door graphics

COST OF IMPROVEMENT (Include only hard costs, no permits, architectural fees, etc.
Attach proposed contractor's agreement) \$ 9446.98. You must provide three (3) bids; grant
cannot exceed \$5,000.

TOTAL PROJECT AMOUNT \$ 9446.98.

GRANT AMOUNT \$ 4723.49

**A. AGREEMENT TO FOLLOW PERTH AMBOY BUSINESS IMPROVEMENT
(PA BID) PROGRAM AND DESIGN GUIDELINES:**

- a. The business must be an active UEZ certified business with the New Jersey Urban Enterprise Zone Program and must remain in the program for at least five (5) years from the date of approval of this application.
- b. The applicant hereby agrees to abide by the design guidelines developed by the PA BID for approval before construction. The City of Perth Amboy will provide a construction permit only upon submission of a Letter of Authorization from the PA BID. If the subsequent construction deviates from the PA BID authorization, the applicant will be solely responsible for the removal of the non-conforming improvement and the PA BID reserves the right to cancel the façade improvement grant.

FR, DEC 10 2021 PM 2:50

B. AWARD FORMULA

The Perth Amboy BID will reimburse the application for hard cost expenses based on the following schedule:

50% of first \$10,000

Total \$5,000

C. SUPPLEMENTAL DOCUMENTATION NEEDED

The applicant must provide the following attachments with the application. The PA BID office can provide, if needed:

- a. Current Perth Amboy UEZ certificate or letter of waiver signed by Noelia Colon, UEZ Coordinator (form 3)
- b. Payment of current commercial property taxes via copy of paid bill or certification from Perth Amboy Tax Collection Department (form 1)
- c. Letter of authorization from property owner for improvements planned if the applicant is not the property owner (form 2)
- d. Proposed contractor's agreement
- e. If improvements are to be made by for tax-exempt tenant, the commercial property owner must be the applicant and must choose option to receive the façade improvement grant or direct PA BID to pay tenant (form 2)

D. REMINBURSEMENT DOCUMENTATION

If the application is accepted, the applicant understands that the façade improvement grant will be awarded on a reimbursement basis and that the applicant must first pay the contractor in full from its own funds. Before the grant is awarded, the applicant must provide:

- a. Copy of cancelled checks paid to the contractor(s) in the amount specified under the "Cost of Improvement"
- b. Paid receipt or contact stamped "Paid in Full" from the contractor(s) in the amount specified under "Cost of Improvement."
(Failure to provide documents will result in a delay of awarding the grant and may result in forfeiture of the grant).

E. GRANT REFUND IF BUSINESS IS CLOSED

The applicant hereby agrees that if the business closes within one (1) year after the completion of the project and the award of the grant (not the acceptance of the application,) the grant will be refunded to the PA BID.

F. APPLICATION NOTIFICATION

The PA BID Façade Committee meets monthly, generally during the second week of the month. Applications must be submitted to Noelia Colon, BID Executive Director, at the PA BID office, 260 High Street, Perth Amboy, NJ, 08861, by the last day of the prior month, to be considered at the next Façade Committee Meeting. Notification will be made to the applicant within two weeks of the committee meeting.

G. GRANT ALLOCATIONS

Due to the demand for façade improvement grants and the limited amount of funds, only one grant per property can be awarded per year, unless separate and distinct tenants within the same building apply for separate and distinct grant.

I, Aleah Multi Services Center LLC, applicant for a Façade Grant, hereby attest that I have read this application in full and understand and agree to all its terms.

APPLICANT

Luiza Gomez

Signature

Luiza M. Gomez Martinez

Name (please print)

DATE: 12/09/2021

VERIFICATION OF PAYMENT OF COMMERCIAL PROPERTY TAX

TO: City of Perth Amboy
FROM: Perth Amboy BID – Façade Improvement Program

The commercial property owner/business owner listed below has applied for a façade improvement grant from the Perth Amboy BID. Among our requirements is verification that payment of the commercial property tax on the property or building be current. Kindly verify below the most recent tax period paid on the subject property.

PROPERTY LOCATED AT: 313 State Street Suite 103
(Street Address)

Lot Number _____ Block Number _____ Classification _____

Property Owner: _____

Business Owner: _____

MOST RECENT TAX PAYMENT HISTORY

Are there any tax liens and/or tax sale certificates on the property?

Yes _____ No

Most Recent Payment Amount: \$ 22,734.29

Most Recent Tax Period Covered: 10-1-2021 to 12/31/2021
(Applicant may also submit a tax payment history print out from the Tax Collector’s Office)

PERTH AMBOY TAX COLLECTOR’S DEPARTMENT
AUTHORIZED SIGNATURE:

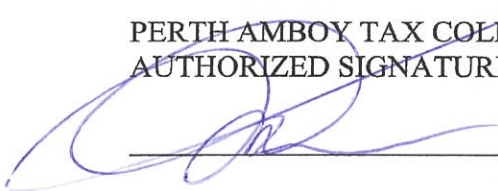

NANCY MARTIN
Name (please print)

Thank you for your cooperation. Should you have any questions, please contact the Perth Amboy BID office at: (732) 442-6421. Please give this form to applicant once completed to complete the application packet.

PROPERTY OWNER’S AUTHORIZATION OF TENANT’S FAÇADE

VERIFICATION OF PAYMENT OF COMMERCIAL PROPERTY TAX

TO: City of Perth Amboy
FROM: Perth Amboy BID – Façade Improvement Program

The commercial property owner/business owner listed below has applied for a façade improvement grant from the Perth Amboy BID. Among our requirements is verification that payment of the commercial property tax on the property or building be current. Kindly verify below the most recent tax period paid on the subject property.

PROPERTY LOCATED AT: 313 State Street, Perth Amboy, NJ 08861
(Street Address)

Lot Number 14 Block Number 126 Classification _____

Property Owner: ETC TOWER LLC

Business Owner: _____

MOST RECENT TAX PAYMENT HISTORY

Are there any tax liens and/or tax sale certificates on the property?

Yes _____ No X

Most Recent Payment Amount: \$ _____

Most Recent Tax Period Covered: _____

(Applicant may also submit a tax payment history print out from the Tax Collector’s Office)

PERTH AMBOY TAX COLLECTOR’S DEPARTMENT

AUTHORIZED SIGNATURE:

Name (please print)

Thank you for your cooperation. Should you have any questions, please contact the Perth Amboy BID office at: (732) 442-6421. Please give this form to applicant once completed to complete the application packet.

PROPERTY OWNER’S AUTHORIZATION OF TENANT’S FAÇADE

-
-
-
-
-
-
-
-
-

Block: 126

Lot: 14

Notes Exist

Qualifier:

Owner: ETC TOWER, LLC C/O ETC MANAGEMENT

Prop Loc: 313 STATE ST.

Account Id: 00002520

General	Assessed Value	Additional	Billing	Deductions	Balance	All Charges	Add/Omit	Notes
Year	Qtr	Type	Billed	Principal Balance	Interest	Total Balance		
2022	2		27,806.10		27,806.10	.00	27,806.10	
2022	1		27,806.10		27,806.10	.00	27,806.10	
2022		Total	55,612.20		55,612.20	.00	55,612.20	
2021	4		27,734.29		.00	.00	.00	
2021	3		27,734.30		.00	.00	.00	

Other Delinquent Balances:

.00 Interest Date: 12/10/21

Other APR2 Threshold Amt:

.00 Per Diem:

.0000

Last Payment Date:

11/05/2021

TOTAL TAX BALANCE DUE

Principal: .00

Penalty: .00

Misc. Charges: .00

Interest: .00

Total: .00

IMPROVEMENT APPLICATION AND/OR REQUEST TO APPLY

TO: Owner Property at 313 State St. Perth Amboy, NJ
FROM: Perth Amboy Business Improvement District Façade Improvement

Dear Property Owner:

Your tenant Alzah Mustafa Services Center LLC has submitted an application for a Façade Improvement at the property listed above. Your authorization as property owner is required to process this application. The tenant proposes the following improvement.

Install Channel letter exterior sign +
window & door graphics

Please indicate whether you support your tenant's application. Yes No

[Signature]
Property Owner Signature

Edward Trujillo
Name (please print)

FOR PROPERTY OWNERS WITH "TAX EXEMPT" TENANTS

Since the tenant does not operate a commercial business and is exempt from paying commercial property taxes, it is technically ineligible for a faced improvement grant, which can only be awarded to property owners, and/or business owners who pay the PA BID tax surcharge onto their commercial property taxes. Therefore, you as the payer of the commercial property tax and PA BID tax surcharge must apply for the façade improvement grant for your building.

A Façade Improvement Grant application is attached. Kindly complete the form and apply directly on behalf of your tenant.

If you want to PA BID Reimbursement payment to be paid directly to your tenant, you must authorize here: Yes No

Your Name: Edward Trujillo
(Please print)

Your Signature: [Signature]

Phone: 732-324-0300

Fax: _____

Date: 12/10/2021

Note: All façade grant carry the stipulation if the improved building is marketed for sale and/or sold within one year after the project completion and award of the grant (not the acceptance of the application) the grant will be refunded in full to the PA BID. Thank you for you cooperation. Any questions, please call the BID office at (732) 442-6421. Once this form is completed, please give it to the tenant to return the same to the BID for further processing



DESIGN - FABRICATION - INSTALLATION

891 State St., Perth Amboy NJ 08861
P. (732) 442-8080 • F. (732) 442-3113

QUOTE

Location Information: 313 State St. Suite 103, Perth Amboy 08861	Client Name: Aleah Multi Services Address: 313 State St. Suite 103, Perth Amboy 08861 Contact: Luisa 732-347-4576	Quote Date: 12/08/21 Project #: Quote #: 10745 Questions? 732.442.8080 Infosales.la@gmail.com
Requested Amount to Start Production: \$4,723.49		

DESCRIPTION:

- 1- Set of Front-Lit Channel Letters
 Reading: "Aleah Multi Service" w/ Logo
 Logo: 30"X 28" / ALEAH: 19"X 100" / MULTI SERVICES: 10"
- 2- 7'X 6' Window Lettering
 Reading: List of 9 Services (SPA and ENG)
- 2- 7'X 6' Full Color Window Graphics
 Reading: Logo and Business Hours
- 1- Door Graphic
 Reading: Logo and Hours of Operation
- 1- Sealed Engineered Drawing (For Sign Permit)



TOTAL PROJECT COST: \$8,860.00 + \$586.98 (NJ Sales Tax) = \$9,446.98

*Price includes all materials, labor, and equipment to produce and install this project.
 Price does not include electrical line, final electrical connection, or permit city fees.*

Payment Options

50% Deposit Required to Start Production: \$4,723.49
 Balance COD: \$4,723.49

1st Payment: _____ 2nd Payment: _____

THANK YOU FOR DOING BUSINESS WITH US!

Updated
12/13/2021

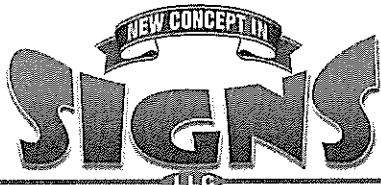

DESIGN - FABRICATION - INSTALLATION

891 State St., Perth Amboy NJ 08861
P. (732) 442-8080 • F. (732) 442-3113

QUOTE

Location Information: 313 State St. Suite 103, Perth Amboy 08861	Client Name: Aleah Multi Services Address: 313 State St. Suite 103, Perth Amboy 08861 Contact: Luisa 732-347-4576	Quote Date: 12/08/21 Project #: Quote #: 10745 Questions? 732.442.8080 Infosales.nc@gmail.com
Requested Amount to Start Production: \$4,723.49		

DESCRIPTION:

- 1- Set of Front-Lit Channel Letters
Reading: "Aleah Multi Services" w/ Logo
Logo: 19"X 19" / ALEAH: 18"X 100" / MULTI SERVICES: 10"
- 2- 7'X 6' Window Lettering
Reading: List of 9 Services (SPA and ENG)
- 2- 7'X 6' Full Color Window Graphics
Reading: Logo and Business Hours
- 1- Door Graphic
Reading: Logo and Hours of Operation
- 1- Sealed Engineered Drawing (For Sign Permit)



TOTAL PROJECT COST: \$8,860.00 + \$586.98 (NJ Sales Tax) = \$9,446.98

*Price includes all materials, labor, and equipment to produce and install this project.
Price does not include electrical line, final electrical connection, or permit city fees.*

Payment Options

50% Deposit Required to Start Production: \$4,723.49
Balance COD: \$4,723.49

1 st Payment: _____	2 nd Payment: _____
THANK YOU FOR DOING BUSINESS WITH US!	

Atlantic

SIGNS & AWNINGS

160 Passaic Ave. Kearney NJ. 07032
 Tel: 732-955-0595 Fax: 201-955-0596

INVOICE NUMBER

12 092100

Aleah Multi Services

313 State St. Suite 103

Perth Amboy, NJ

732-347-4576

Aleah Multi Services

313 State St. Suite 103

Perth Amboy, NJ

732-347-4576

Luisa M.

732-347-4576

Ordered By

Phone

Date 12-09-2021	P.O.P.	Terms. COD	Sales Rep. Richard Hara
--------------------	--------	---------------	----------------------------

QUANTITY	DESCRIPTION	UNIT PRICE	AMOUNT
1	Logo and channel letter sign Reading: Aleah Multi Service w/Logo Size: 30" logo, 19" Aleah and 10" MS Colors: Royal blue And Baby blue	6,380.00	6,380.00
4	84"x72" Window and 1- Door Graphic.	1,645.00	1,645.00
1	Installation	1,935.00	1,935.00
<i>Permit or permit related cost not included in the price</i>			
<i>Electrical connection by other</i>			

CASH	CHECK #	VISA	MC	CHARGE	TAX EXEMPT #	Subtotal	9,960.00
------	---------	------	----	--------	--------------	----------	----------

IN THE EVENT OF NON-PAYMENT Customer Agrees:
 *All products will remain property of ATLANTIC SIGNS & AWNINGS until paid in full.
 The SIGN can be removed from property without notice.
 *The removal and re-installation of the sign will be added to the final invoice.
 *We will proceed with a Legal Collection done by our COLLECTION ATTORNEY,
 the BUYER agrees to have all the expensive added to the final invoice.

Tax	N/A
Shipping	N/A
TOTAL	9,960.00
Deposit	
BALANCE DUE	

SIGNATURE

DATE



PrintMediaOnline

254 Highway 34, Suite 4
Matawan, NJ 07747
Tel: 732-705-3313 • order@printmediaonline.com

Estimate

Date	Estimate #
12/08/2021	108672
Exp. Date	
N/A	

Address
Aleah Multi Services 313 State St.(Suite 103) Perth Amboy, NJ 08861 732-347-4576 Luisa Gomez

Quantity	Description	Amount
1	<p><u>CHANNEL LETTER AND LOGO</u></p> <p>1- Logo and channel letter sign (Aleah Multi Service w/Logo) Size: 30" H. logo, 19" and 10" H. Letters Colors: Dark blue And light blue 4- 84"x72" Window and 1- Door Graphic. Installed</p> <p>PERMITS AND ELECTRICAL CONNECTION BY OTHER</p>	\$8,940.00

SubTotal	\$8,940.00
Tax (6.625%)	EXEMPT
Total	\$8,940.00

Accepted By PPJ

Accepted Date